

4.2: Design of an Improved Pixel for a Polysilicon Active Matrix Organic Light Emitting Diode Display

*R.M.A. Dawson, Z. Shen, D.A. Furst, S. Connor, J. Hsu,
M.G. Kane, R.G. Stewart, A. Ipri*
Sarnoff Corporation, Princeton, NJ.
*C.N. King, P.J. Green, R.T. Flegal, S. Pearson, W.A. Barrow,
E. Dickey, K. Ping*
Planar America, Beaverton, OR
C.W. Tang, S. Van Slyke, F. Chen, J. Shi
Eastman Kodak Company, Rochester, NY
J.C. Sturm, M.H. Lu
Princeton University, Princeton, NJ

Abstract

A polysilicon transistor based active matrix organic light emitting diode (AMOLED) pixel with high pixel to pixel luminance uniformity is reported. The new pixel powers the OLEDs with small constant currents to ensure consistent brightness and extended life. Excellent pixel to pixel current drive uniformity is obtained despite the threshold voltage variation inherent in polysilicon transistors. Other considerations in the design of pixels for high information content AMOLED displays are discussed.

Introduction

Organic electroluminescent devices such as organic light emitting diodes (OLEDs) are presently of great interest due to their potential application in high efficiency, flat panel displays¹. OLEDs were recently demonstrated as the light emitting component in a passively addressed display product². These passive matrix displays demonstrate the feasibility of OLEDs in these applications, but encounter a fundamental barrier as the display size and pixel density increase. Since the luminous output of an OLED is proportional to the charge injected through the device, the current densities required to operate passively addressed displays rapidly rise as the time available to drive each pixel decreases with increasing display resolution. These high currents cause large voltage drops in the ITO lines of the passive array, pushes the

OLED operation to higher voltages and creates display driver issues that are not easily resolved. Moving to an active matrix drive scheme can overcome a number of these issues.

The goal of the active matrix OLED (AMOLED) display is to generate a constant current source at each pixel using thin film transistors which, in this work, were made in a polysilicon technology. Each pixel is programmed to provide a constant current during the entire frame time, eliminating the high currents encountered in the passive matrix approach. However, polysilicon thin film transistors suffer from significant initial output characteristic non-uniformity due to the nature of the polysilicon crystal growth. This makes it difficult to create a uniform current source at each pixel. A new AMOLED pixel was designed which addresses this issue and results will be presented which show the improved performance compared to a standard pixel.

Pixel Uniformity

The most critical issue in the design of an AMOLED pixel is the pixel to pixel luminance uniformity. Driving the OLED with a constant current provides the best pixel to pixel uniformity since the OLED threshold variations no longer impact the charge passed through the devices^{2,3}. This requires that the active components at each pixel of the AMOLED display provide a constant current to the OLED. OLEDs are presently fabricated with the anode

connected to the ITO on the active matrix plate and the cathode connected to a metal alloy back plane such as Mg:Ag or Al:Li. The effect of OLED threshold variations can be eliminated by using a PMOS device on the active plate since the OLED will be connected to the drain of the PMOS transistor. In this configuration, the transistor will provide a constant current to the OLED as long as the transistor stays in saturation. If an NMOS device were used on the active matrix plate, the OLED would be connected to the source of the transistor and additional techniques would be needed to ensure that the OLED threshold variation did not affect the gate to source voltage of the transistor. PMOS polysilicon devices are available, so the pixel designs studied here use a PMOS device to drive the OLED and the transistor is operated in saturation to overcome the OLED threshold variations. The simplest pixel, shown in Fig. 1, uses two transistors: one drives the current for the OLED, MP2, and another, MP1, acts as a switch to sample and hold a voltage on the gate of the drive transistor.

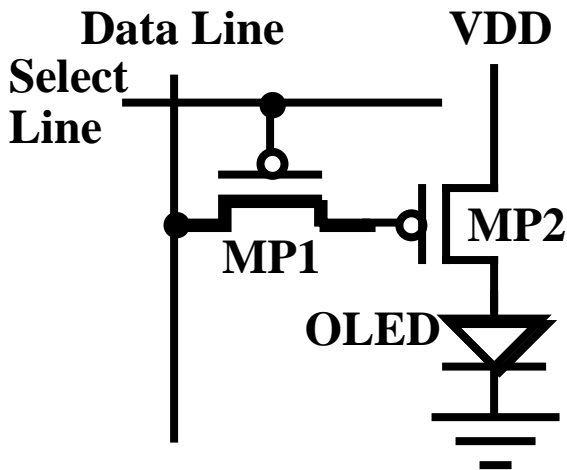

Fig. 1. Two-Transistor AMOLED Pixel.

The major cause of luminance non-uniformity in the two-transistor pixel is the variation in the drive transistor MP2. This transistor has a high level of output characteristic variation due to the nature of the polysilicon grain growth. This local non-uniformity can be improved by process refinements⁴, but it is difficult to reduce the variation across the array to a level necessary for good gray scale control. For

example, if the pixel configuration of Fig. 1 was designed to provide maximum brightness with 3 volts of overdrive on the drive transistor, MP2, then the voltage division for one gray level with 8 bits of gray scale is $3 \text{ volts}/256 = 12 \text{ mV}$. The threshold variation across the 2.7 inch diagonal display in Ref. 4 was 300 mV with local variations on the order of 100 mV. These numbers indicate that, even with a high quality process, the transistor threshold variations are much too large to provide the pixel to pixel uniformity necessary for a high quality flat panel display. This conclusion is confirmed in Fig. 2 which shows the visible effects of transistor non-uniformity on the two-transistor pixel design of Fig. 1.

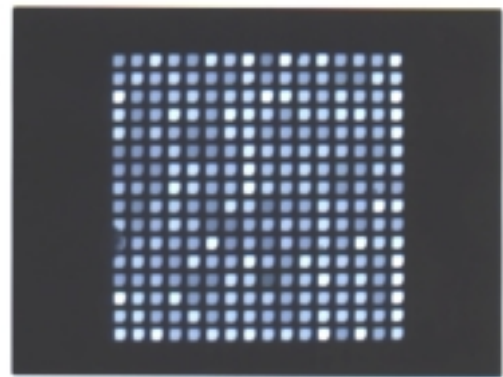

Fig. 2. Luminance non-uniformity of the two-transistor pixel caused by local variations in the transistor output characteristics.

An improved AMOLED pixel was designed which eliminates the effects of the polysilicon transistor threshold voltage variation. The schematic for this pixel is shown in Fig. 3 and a timing diagram which describes its operation is shown in Fig. 4.

The advantage of the four-transistor pixel is that it uses an autozero cycle to reference the data against the transistor threshold voltage, eliminating the effects of the transistor threshold voltage variation. The improvement can be seen by comparing Figs. 2 and 5 where there is an obvious, visible improvement in the pixel to pixel luminance uniformity in the four-transistor test pixel array.

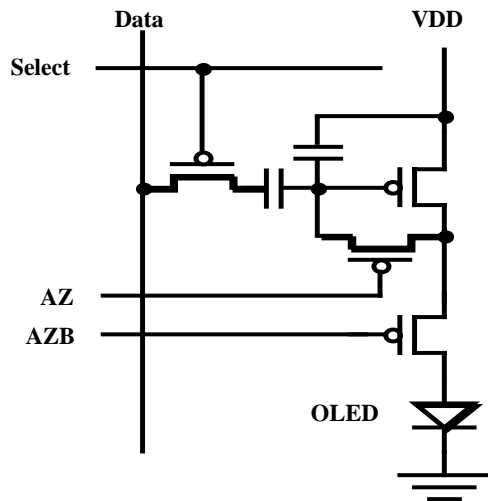

Fig. 3. Schematic of Four-Transistor AMOLED Pixel with Autozero.

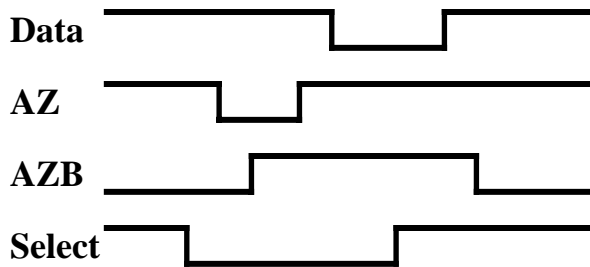

Fig. 4. Four-Transistor AMOLED Pixel Timing Diagram

Most importantly, the four-transistor pixel has much better performance at low luminance levels which allows for accurate gray scale control. This is quantified in Fig. 6 where normalized pixel luminance is shown for sixteen two-transistor and sixteen four-transistor pixels at an areal, array luminance of 15 nits. The standard deviation of the pixel luminance at an areal, array luminance of 150 nits and 15 nits is presented in Table 1. The table shows that the four-transistor pixel improves the pixel luminance variation by almost a factor of four at the two areal luminance levels.

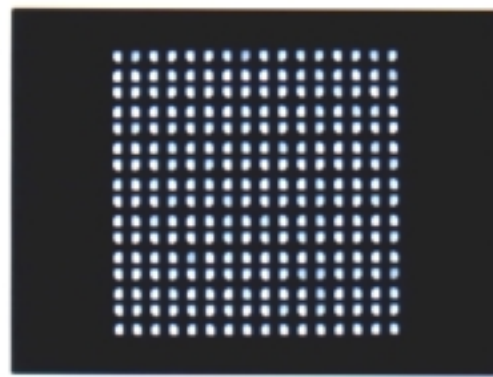

Fig. 5. Four-transistor pixel array showing excellent pixel luminance uniformity.

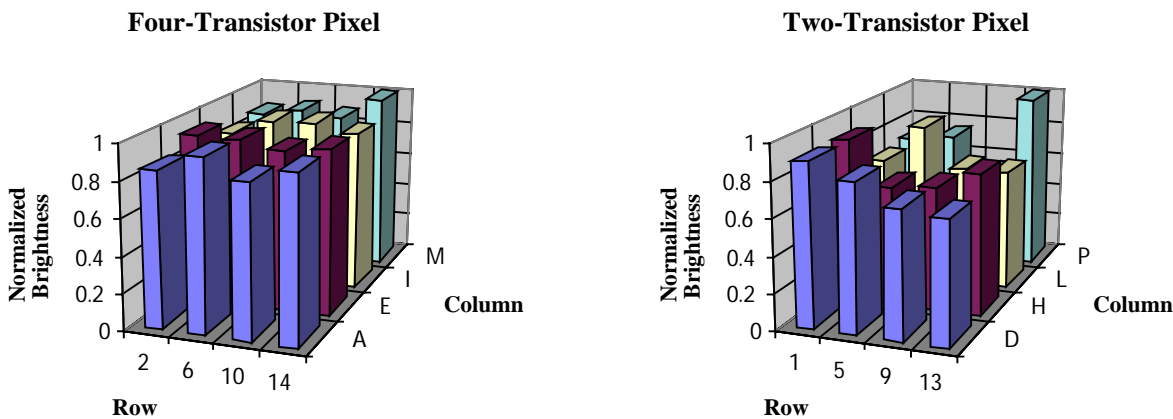

Fig. 6. Normalized pixel luminance uniformity of the two-transistor pixel and the four-transistor pixel at an areal luminance of 15 nits.

Array Areal Luminance	2-Transistor Pixel Lum. Std. Dev.	4-Transistor Pixel Lum. Std. Dev.
150 nits	10.1%	2.6%
15 nits	16.1%	4.7%

Table 1. Standard deviation of the pixel to pixel luminance for the two and four transistor pixel arrays at 150 nits and 15 nits.

Other Pixel Design Considerations

Power dissipation in an OLED display is a critical issue. Measurements and modeling show that the temperature increase due to power dissipation in the active plate and in the OLEDs can be severe because the heat transfer from the display to the ambient is relatively inefficient.⁵ It is essential that the active matrix electronics consume a minimum of power since the OLEDs themselves dissipate power while generating light. It is important to note that while the OLEDs dissipate considerable power, the overall efficiency can be over 3 lm/W with all the drive electronics⁶ while AMLCDs are typically 1 to 2 lm/W. The design trade off to address in the active matrix electronics design is that, while some power must be consumed in order to provide current control, this power must be kept to a minimum. Reduced power dissipation in the supporting electronics leads to a smaller control voltage range with a subsequent requirement of more accurate electronics. The electronics must provide the necessary gray scale control while dissipating as little power as possible.

Finally, the pixel should use a minimum of control lines, storage capacitors and transistors. For example, the two-transistor pixel of Fig. 1 requires two transistors, select and data control lines, one power line and a storage capacitor. The four-transistor pixel requires more components than the two-transistor pixel. This may be the greatest weakness of the four-transistor pixel but the extra devices are essential to provide the necessary pixel to pixel luminance uniformity.

Summary

Active matrix organic light emitting diode pixels were designed and demonstrated. An improved, four-transistor pixel showed a four fold improvement in pixel to pixel luminance uniformity compared to the basic two-transistor pixel. This improvement was attained by referencing the data to the pixel transistor threshold voltage, eliminating the effects of the polysilicon transistor threshold voltage variations. The next steps in this investigation are to further improve the AMOLED pixels and fabricate a display to demonstrate the effectiveness of the new pixel design.

Acknowledgment

This work is supported by Bruce Gnade of the Defense Advanced Research Projects Agency (DARPA) under contract F33615-96-2-1944 monitored by Gurdial Saini and Darrel Hopper of Wright Laboratory, Displays Branch.

References

1. IEEE Trans. on Electron Devices, August, 1997. Special Issue on Small Molecule and Polymer Organic Devices.
2. T. Tohma, "Recent Progress in Development of Organic Electroluminescent Display Devices," Society for International Display, International Display Research Conference Proc., 1997, p. F-1.
3. S.A. Van Slyke, C.H. Chen and C.W. Tang, "Organic Electroluminescent devices with Improved Stability," Appl. Phys. Lett. 69, (1996), p. 2162.
4. H. Sekine, H. Asada, Y. Ogawa, K. Ozawa, K. Mochizuki, F. Okumura, and S. Kaneko, "Amplifier Compensation Method for a Poly-Si TFT LCLV with an Integrated Data-Driver," Society for International Display, International Display Research Conference Proc., 1997, p. 45.
5. J.C. Sturm, W. Wilson, and M. Iodice, "Thermal effects and scaling in organic light emitting flat panel displays," accepted for publication, IEEE J. Selected Topics in Quant. Elect., 1998.

6. T. Tohma, Presented at the International Display Research Conference, 1997.