



Enhancing Mobility Through Technology in a Congested Urban Environment

**Evolution of Ground Transport Technology:
From the Omnibus
through Personal Rapid Transit (PRT)
to autonomous Taxis (aTaxis)**



The Problem: Urban Congestion Snarls Mobility

Also issues about accessibility and equality of access



Over the years technology has evolved...

From:
Omnibus on Blackfriar's Bridge, 1798

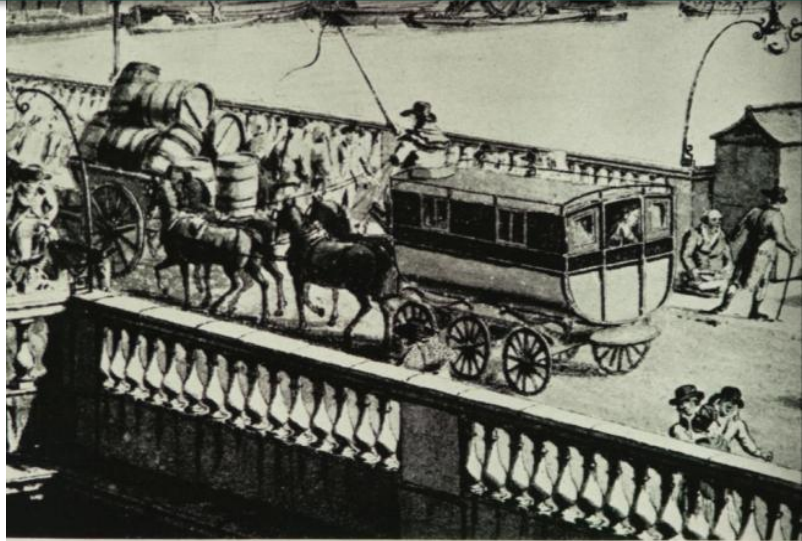

Omnibus on Blackfriars Bridge, 1798

To:
Hummers ~2007 (Pre Crisis)



To:
Prius & Tesla 2015 (?????)



To:
GoogleCars ~ 2017+ ???





Evolution of the OmniBus for intra-urban mass transportation

Start:
London, 1798

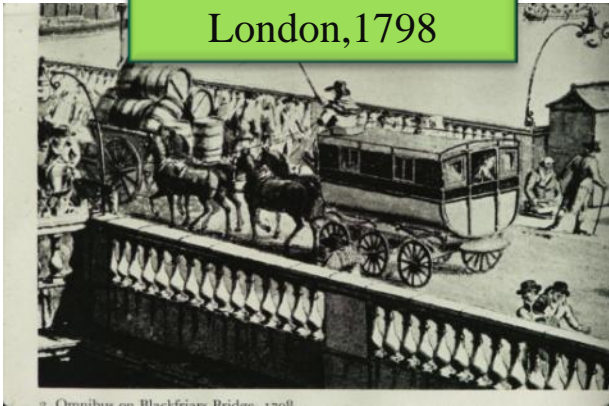

Geo Enhancement:
NYC, 1830



- Technology Elements:**
- Capacity: ~10 Seated Passengers
 - Propulsion: Horses or Mules
 - Externalities: Disease and non-operating revenue from pollution
 - Suspension: Steel Sprung Wooden Wheel with solid axel
 - Way: "Flat" Pavement (stone, wood, compacted earth)
 - Headway & Lateral Control: Human

Capacity Enhancement:
Double Decker, London

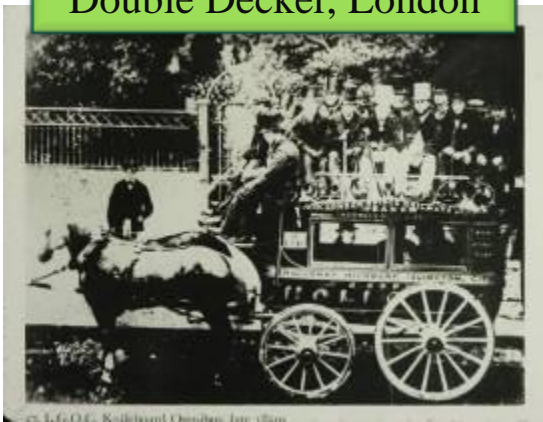

Propulsion Enhancement:
Steam, London

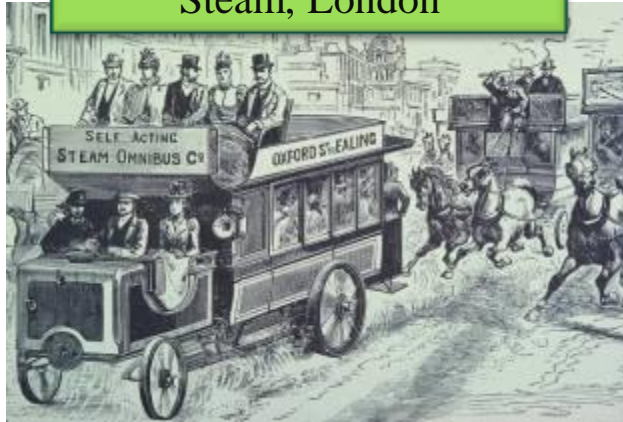

Support Enhancement:
Iron (Steel) Rails

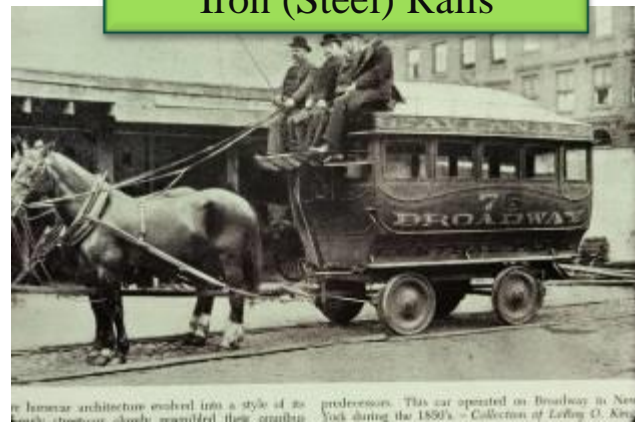



Growth of Horse-Drawn Street Railway Technology

1850: NYC



...the former architect worked into a style of its ...
... This car operated on Broadway in New York using the 1850s. - Collection of LeRoy O. Ang

1860: London



Train's Victoria Street Tram, 1860

1875: Minneapolis

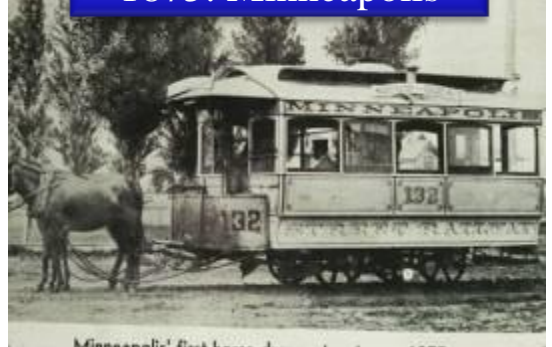

Minneapolis' first horse-drawn streetcar, 1875

1890: Broadway NYC



Discriminating travelers on New York's Third Avenue Railroad rode aboard this richly furnished drawing-room car constructed for the hooscar line in 1871 by the Pullman Palace Car Company. The car made four round trips daily except Sunday. - Courtesy of Pullman Company and Railroad Magazine.

1908: Washington, GA



...all towns and cities the hooscar amenities lingered after the adoption of electric traction elsewhere. The mule-powered Above was still working in Washington, Ga., in 1906. - Library of Congress.



Evolution of Horse-Drawn Street Railway Technology

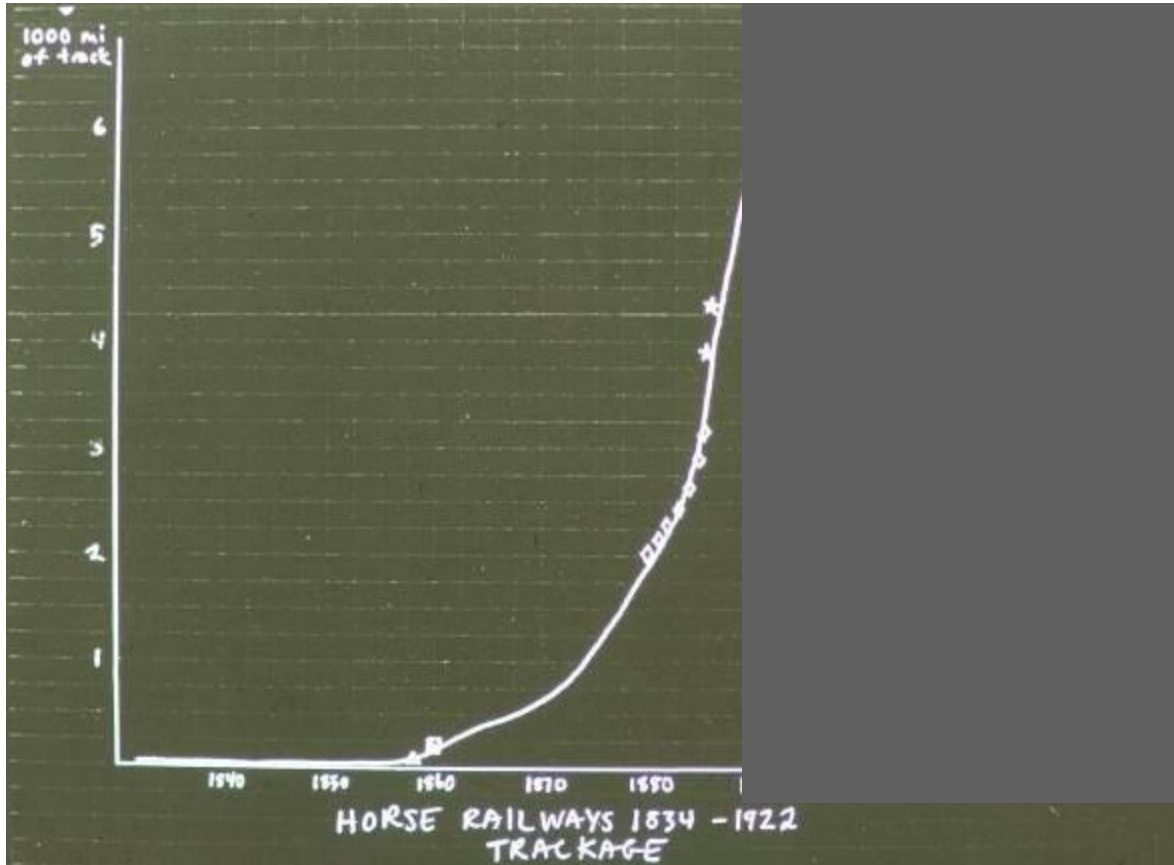

Today: DisneyWorld

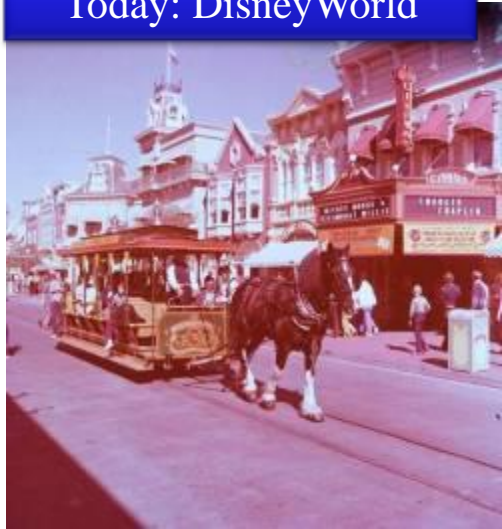

Growth of Cable Street Railway Technology

1880: Washington, DC



Beginning in 1873: San Francisco

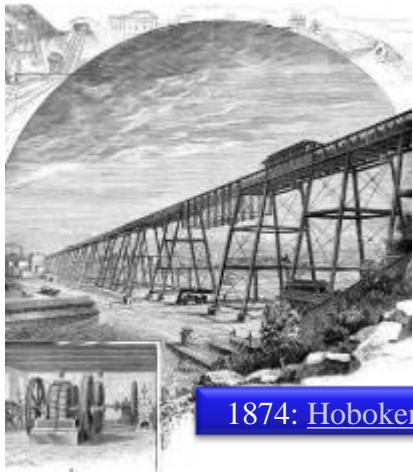

1900: Pittsburgh

1874: Hoboken



1890: Kansas City



1880: Los Angeles

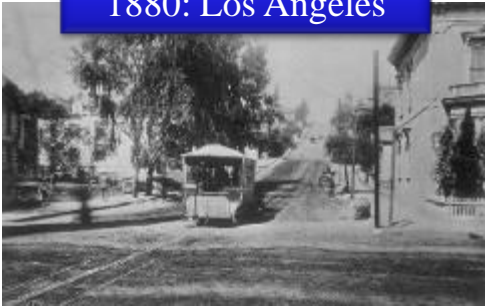

1882: Portland, OR



1896: Cincinnati

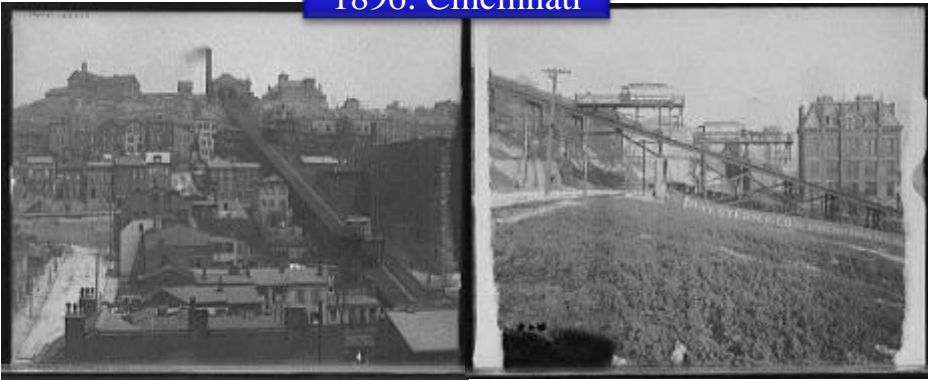

1890: Chicago

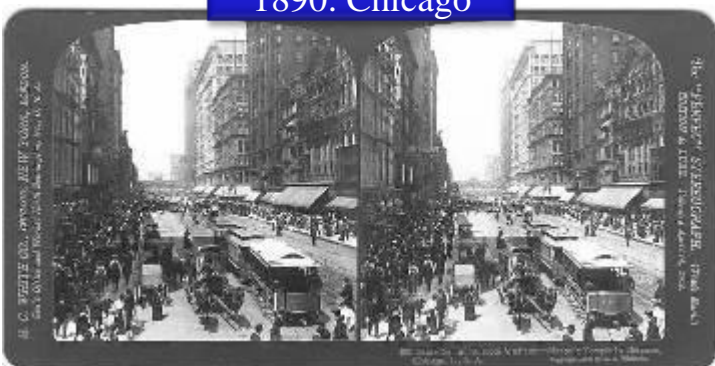

Elements of Cable Street Railway Technology

1886: Steam Power Plant

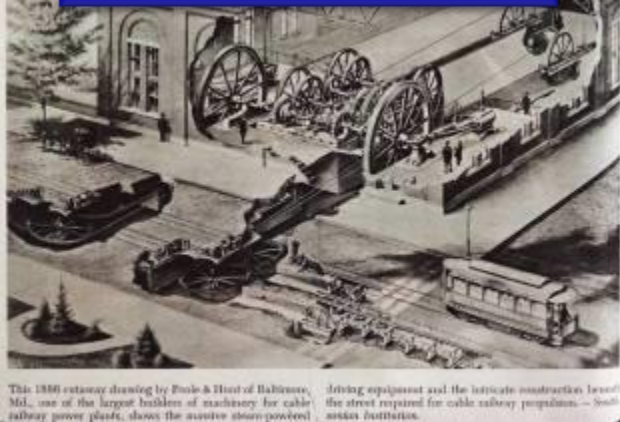

Hoboken Grip

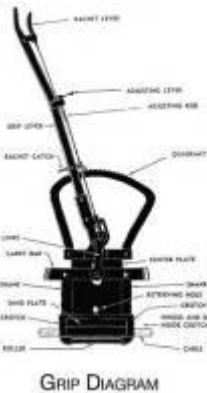
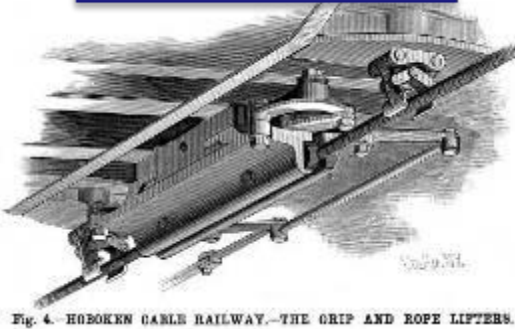

Under the street

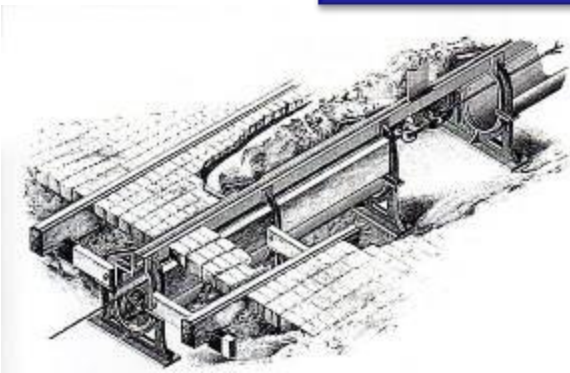



Elements of Cable Street Railway Technology

San Francisco



Interior



Gripper



Let Go xing



Stuck



Push





Evolution of Cable Street Railway Technology

Beginning 1873: SF

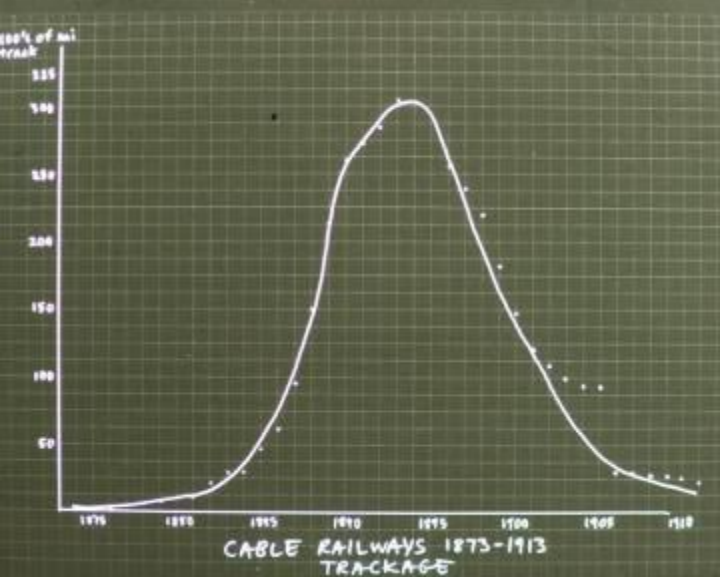
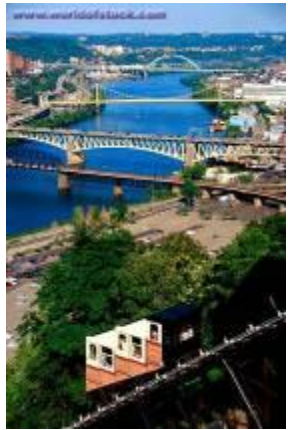
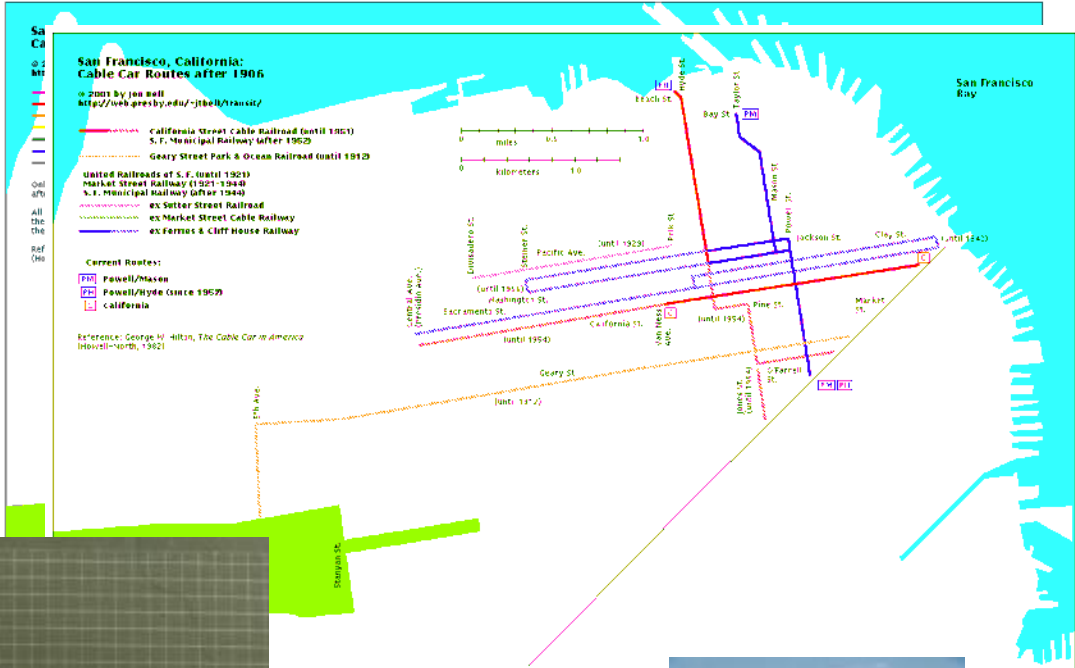



Birth-Death Process of Transport Technology

In the beginning...

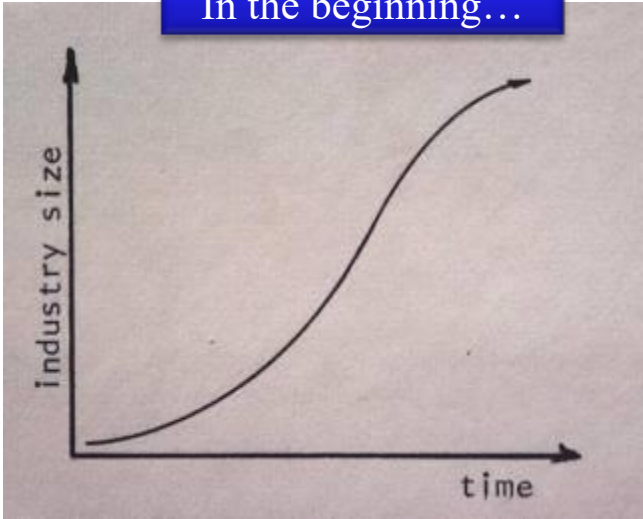

In the end...

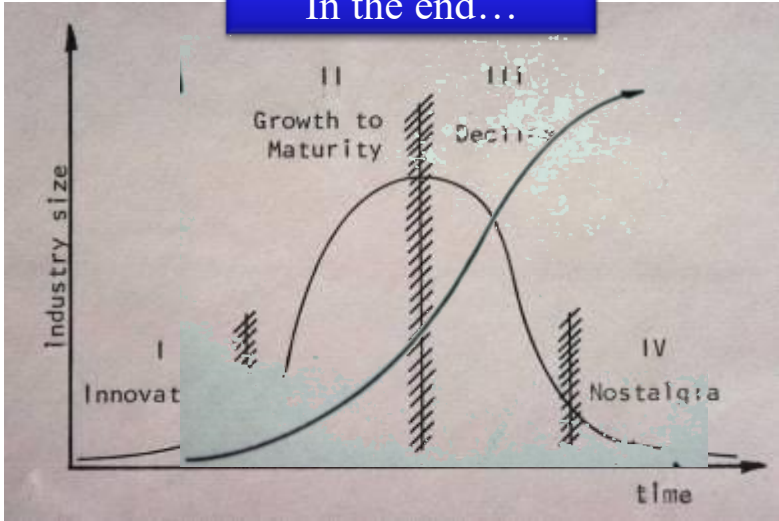

“... [I]n capitalist reality..., it is not [price] competition which counts but the competition from the new commodity, the new technology...- competition which commands a decisive cost or quality advantage and which strikes not at the margins of the profits and the outputs of the existing firms but at their foundations and their very lives.” Joseph A Shumpeter (1883-1950)





2nd half of 19th Century is a period of industrialization and rapid growth of cities

- In response, cities can occupy the same area at a higher density, implying higher congestion, or
- Expand over a larger area, requiring better transportation technology.



Mid-Late 19th C ways to address congestion through segregation of modes

Pedestrian Overpass

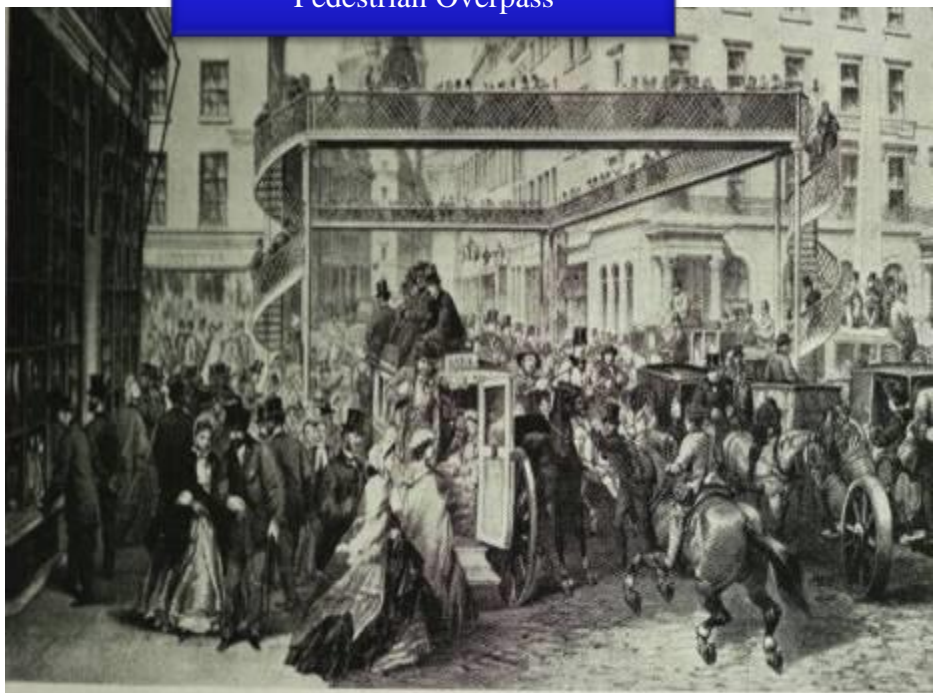

12. A suggested Pedestrian Crossing at Ludgate Circus, mid-19th Century

People over Transport

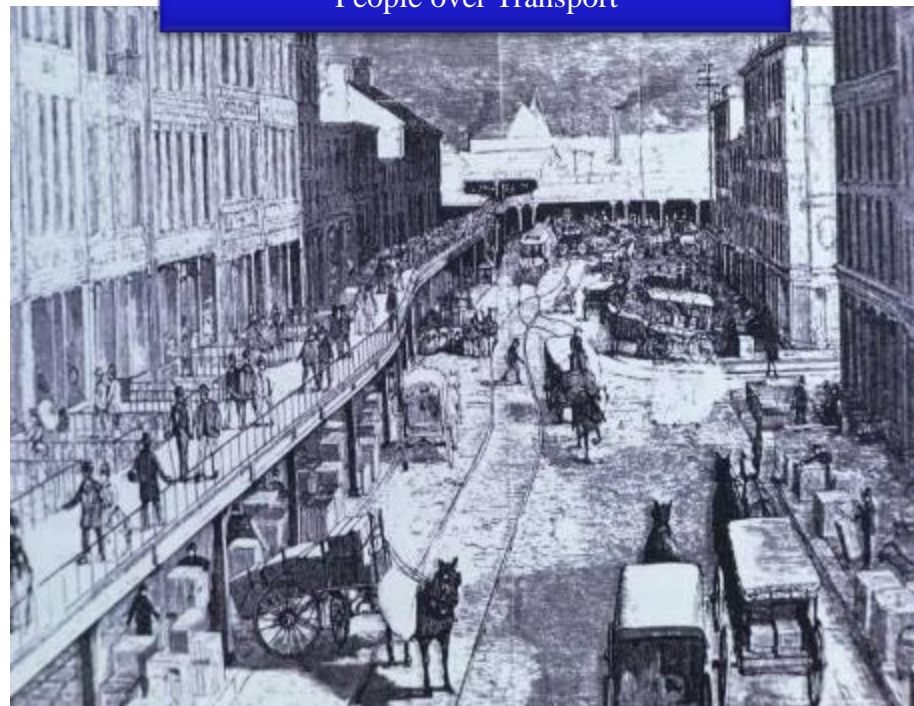



Segregation of Modes

Transport over People

London



NYC

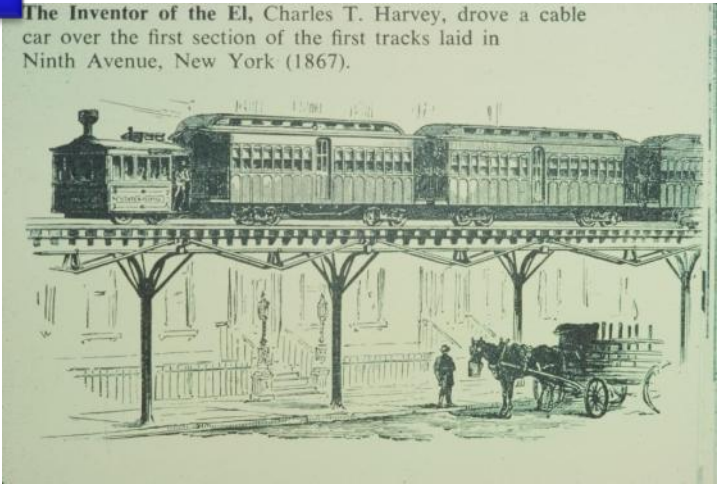

The Inventor of the El, Charles T. Harvey, drove a cable car over the first section of the first tracks laid in Ninth Avenue, New York (1867).



DESIGN PATENTED BY DR. R. H. GILBERT JUNE 26, 1874, FOR AN ELEVATED STRUCTURE TO BE OPERATED WITH STEAM LOCOMOTIVES. Showing proposed diamond sides, telegraph lines, conduits to catch water or droppings, and curved guards to prevent objects falling from the structure to the street. View at Broadway and Vesey Street, looking south, St. Paul's at the right.



PLAN OF AN ELEVATED STREET RAILROAD (STEAM OPERATION) PROPOSED BY GENERAL FRANZ SIGEL, 1872

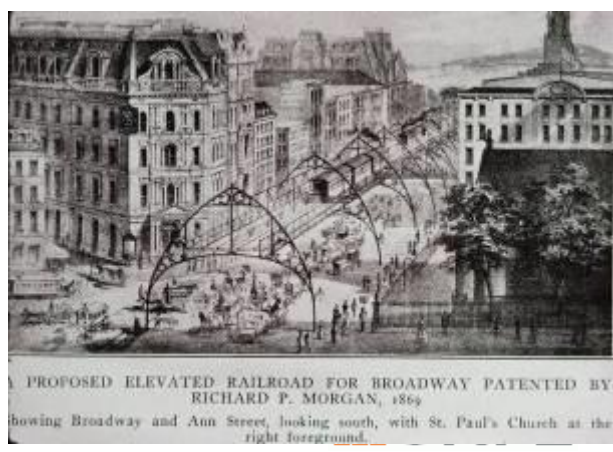

A PROPOSED ELEVATED RAILROAD FOR BROADWAY PATENTED BY RICHARD P. MORGAN, 1869. Showing Broadway and Ann Street, looking south, with St. Paul's Church at the right foreground.



Segregation of Modes

Building the First Elevated RR in NYC

Commenced Service, 7/2/1867 (cable powered, converted to steam 2/14/1883)

The Inventor of the El, Charles T. Harvey, drove a cable car over the first section of the first tracks laid in Ninth Avenue, New York (1867).

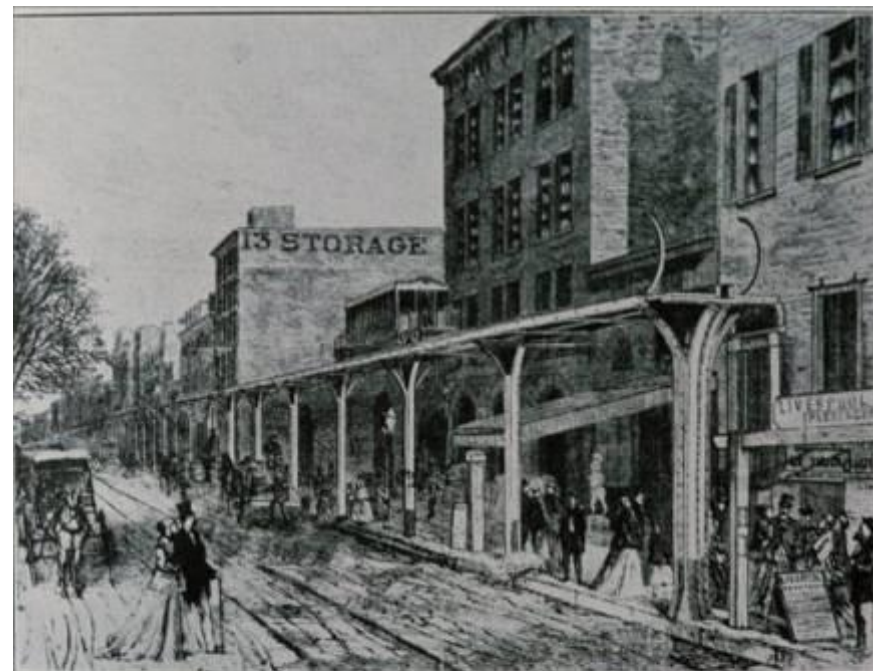
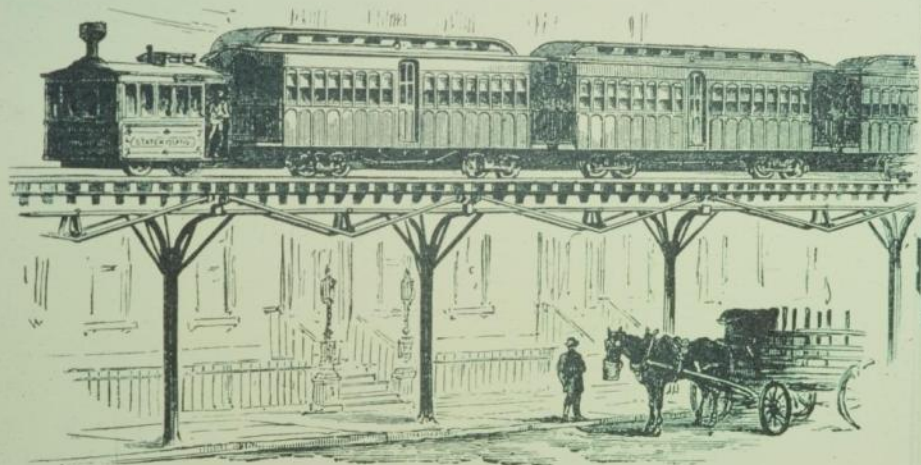

FIRST ELEVATED RAILROAD ON GREENWICH STREET SOUTH OF MORRIS STREET

Built on the easterly curb line, 1867-68.

(From *Harper's Weekly*, July 21, 1868)



Segregation of Modes

Building the First Elevated RR in NYC



GREENWICH STREET LOOKING SOUTHEAST FROM DEY STREET, 1868-69
Showing the elevated structure on the east curb line of Greenwich Street, built in 1868-69, cable used for train operation, showing the first south station at Dey and Greenwich Streets in course of construction.



GREENWICH STREET, LOOKING SOUTHEAST FROM THE CORNER OF FULTON STREET, 1869
Showing the first elevated railroad, erected 1868-69 on the easterly curb line of Greenwich Street in front of the Ocean National Bank, and operated by cable.



Segregation of Modes

Building Elevated RR in NYC



NINTH AVENUE, NORTH FROM GANSEVOORT STREET, MAY, 1876

Showing the elevated structure extending north from the east curb of Greenwich Street to Little West 12th Street, thence on the west curb of Ninth Avenue. The Gansevoort Street turnout is shown extending south on the west side of the extreme north end of Ninth Avenue. The structures were built 1868-69; the first train was run February 14, 1870.



NINTH AVENUE, NORTH FROM 13TH STREET, MAY, 1876

Showing the elevated structure built on the west curb line, 1868-69; the 14th Street Station and Manhattan Street and connections for creating a new turnout structure.



Segregation of Modes

Building Elevated RR in NYC



NINTH AVENUE, NORTH FROM GANSEVOORT STREET, MAY, 1876

Showing the elevated structure extending north from the east curb of Greenwich Street to Little West 12th Street, thence on the west curb of Ninth Avenue. The Gansevoort Street turnout is shown extending south on the west side of the extreme north end of Ninth Avenue. The structures were built 1868-69; the first train was run February 14, 1870.



NINTH AVENUE, NORTH FROM 13TH STREET, MAY, 1876

Showing the elevated structure built on the west curb line, 1868-69; the 14th Street Station and Manhattan Street and connections for creating a new turnout structure.



Segregation of Modes

Building Elevated RR in NYC



NINTH AVENUE, NORTH FROM 43RD STREET, MAY, 1876

Showing the original elevated structures built in 1875-76 on the west curb line; and the new "L" on the roadway, east of the surface car tracks, nearing completion.



TWO-TRACK JOINT STRUCTURE OF THE NEW YORK ELEVATED RAILROAD (NINTH AVENUE LINE) AND THE METROPOLITAN ELEVATED RAILWAY (SIXTH AVENUE LINE) ON NINTH AVENUE (COLUMBUS AVENUE), LOOKING SOUTH FROM WEST 83RD STREET, IN 1878-79

This two-track structure was built from 53rd to 83rd Streets, on Ninth Avenue.



Segregation of Modes

Building Elevated RR in NYC

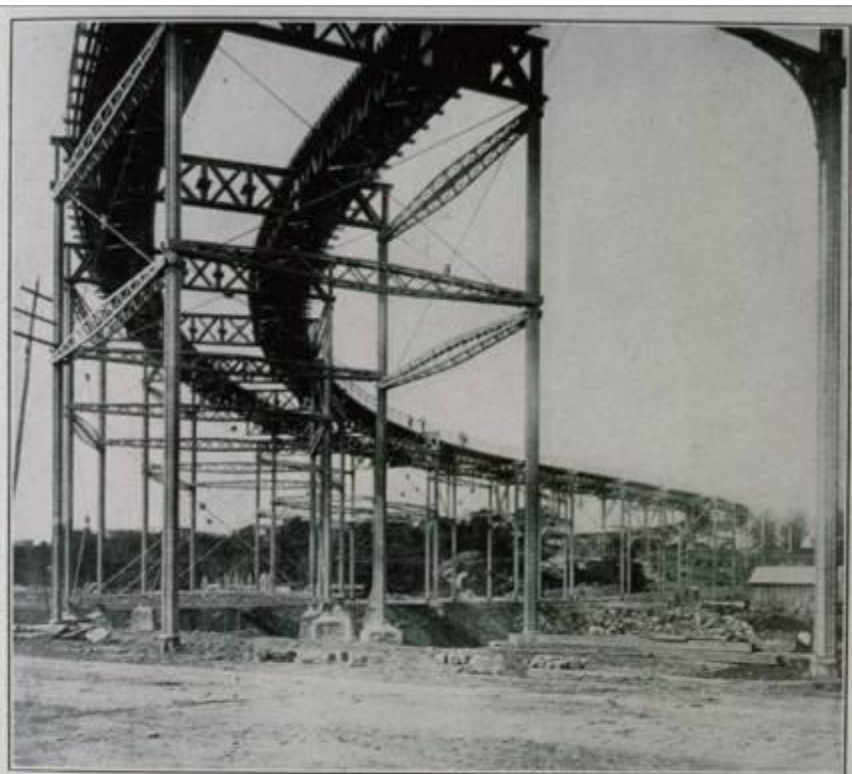

METROPOLITAN ELEVATED RAILWAY STRUCTURE ON 110TH STREET (NOW CATHEDRAL PARKWAY), LOOKING SOUTHWEST FROM EIGHTH AVENUE, 1878-79

In the distance, at the left, Lion Park is shown, located at 109th Street, east side of Ninth Avenue.

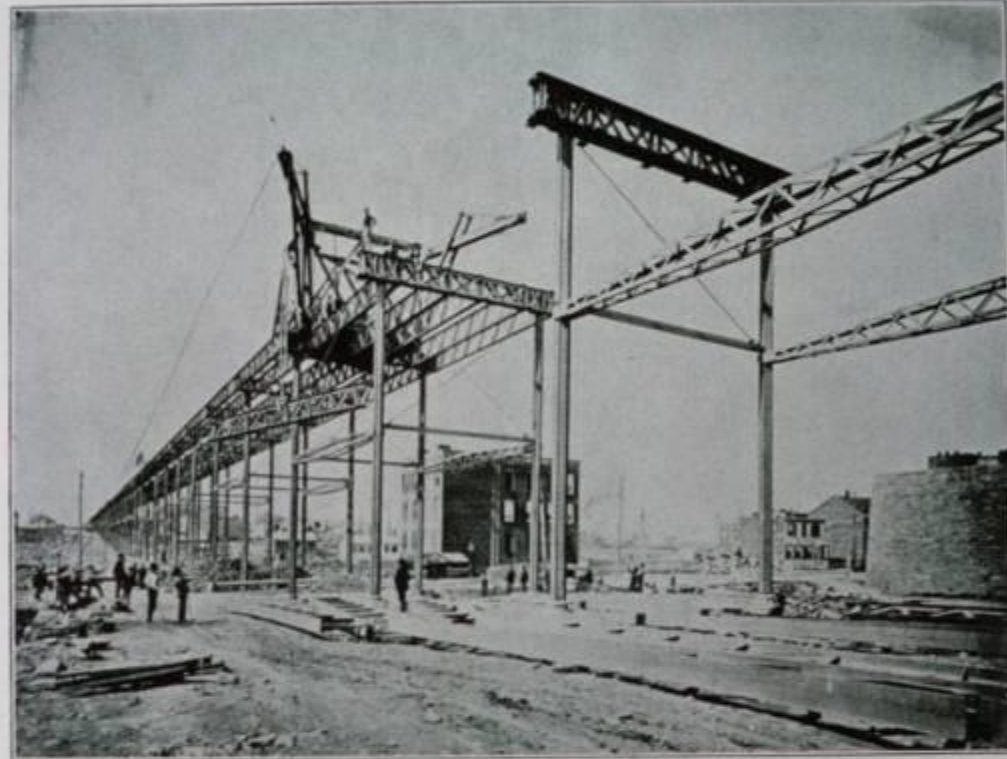

STRUCTURE OF THE METROPOLITAN ELEVATED RAILWAY COMPANY (SIXTH AVENUE LINE) BEING ERECTED ON NINTH AVENUE (COLUMBUS AVENUE) IN 1878-79

One of the highest spots of the elevated structures. Looking southwest from 96th Street. Remains of the old Croton Aqueduct (built in 1842) visible at the extreme right.



Segregation of Modes

Building Elevated RR in NYC

6th Ave Line Station, 1878



6th Ave Line, 1945



2nd Ave Line, 1900



3rd Ave Line

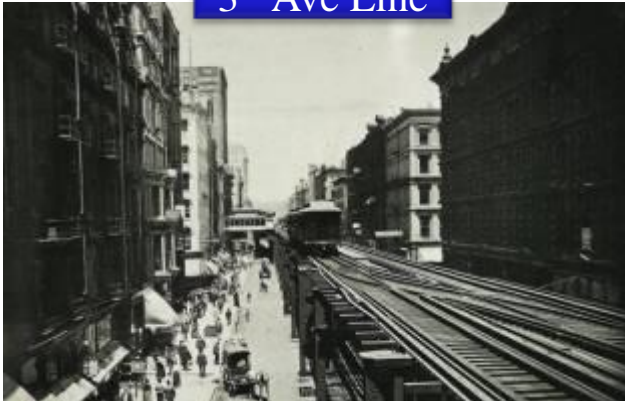

Chicago Loop, 1900

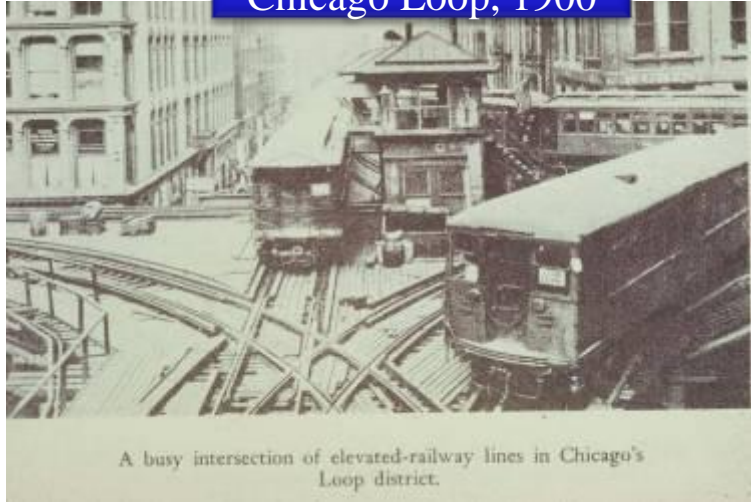



Segregation of Modes

Going Underground: Transport Under People

London, 1860s

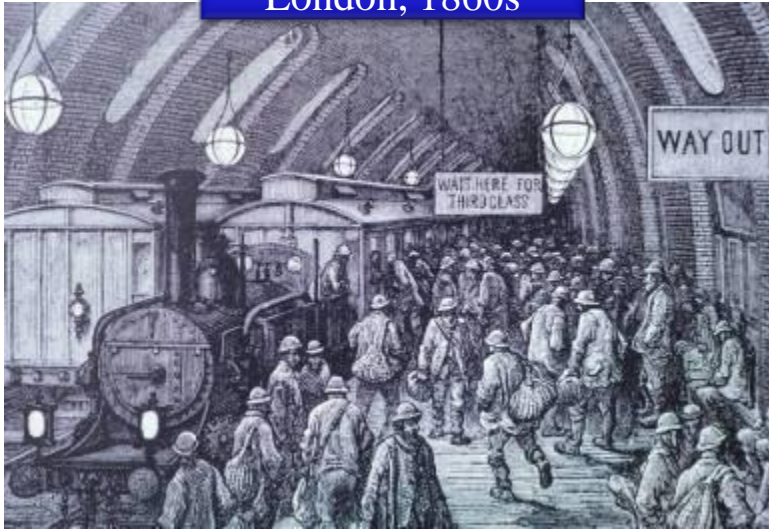

Baker St. Station, London Metropolitan, commenced service 1/10/1863



Cut & cover, Paddington, 1866



NYC Park Ave, 1880



Boston, 1st US, 1904

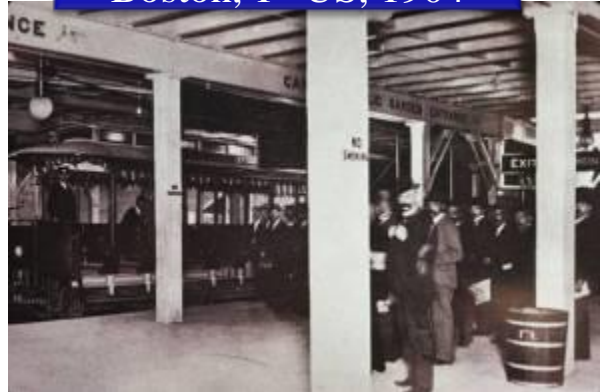



Electric Traction



Innovation of Electric Traction



The Innovators

Thomas Davenport (1802-1851)

an American blacksmith and inventor who invented the first DC electrical motor in 1834 and made a small model of electrical railway in 1835. He patented a device for "Improvements in propelling machinery by magnetism and electromagnetism" in 1837 (his electric railway).



Davenport's model of an electric "train." The circular track is 4 feet in diameter. Power was supplied from a stationary battery to the moving electric locomotive, using the rails as conductors for the electricity

Berlin, 1879



Kurfurstendamm St., 1879



Werner Von Siemens 1816-1892



Montgomery Al., 1882

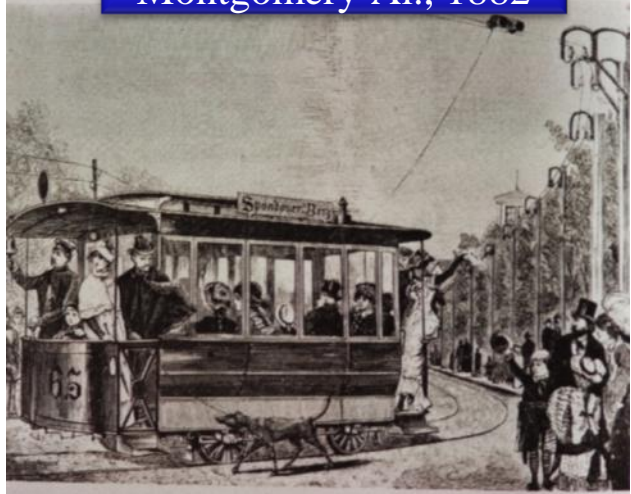



The Innovators

Leo Daft (1843-1922) Baltimore 1885
Uses 3rd rail

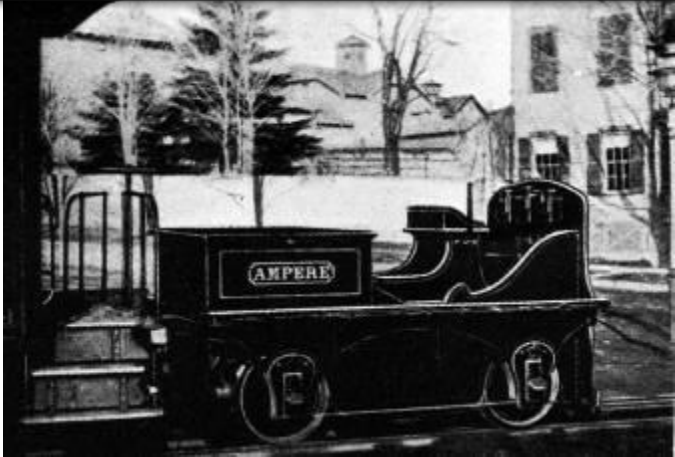

Charles Van Depoele 1846-1892
Chicago Demonstration 1883, overhead wires





1st Really Successful System Richmond, VA, 1888

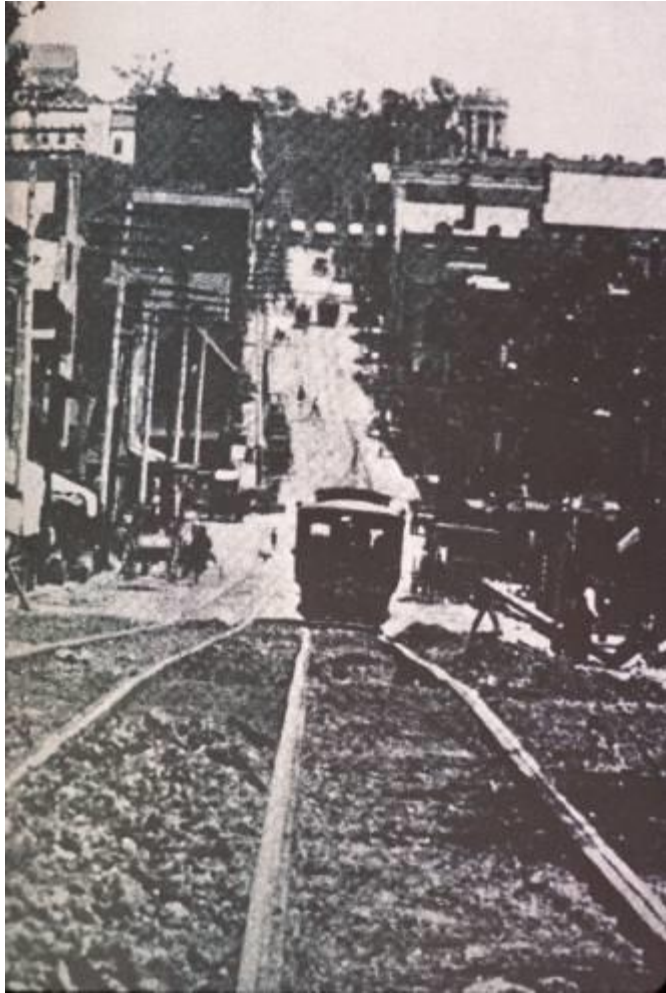

Frank J Sprague 1857-1934





Growth to Maturity of Electric Traction

ELECTRIC RAILWAYS TRACKAGE 1888 - PRESENT

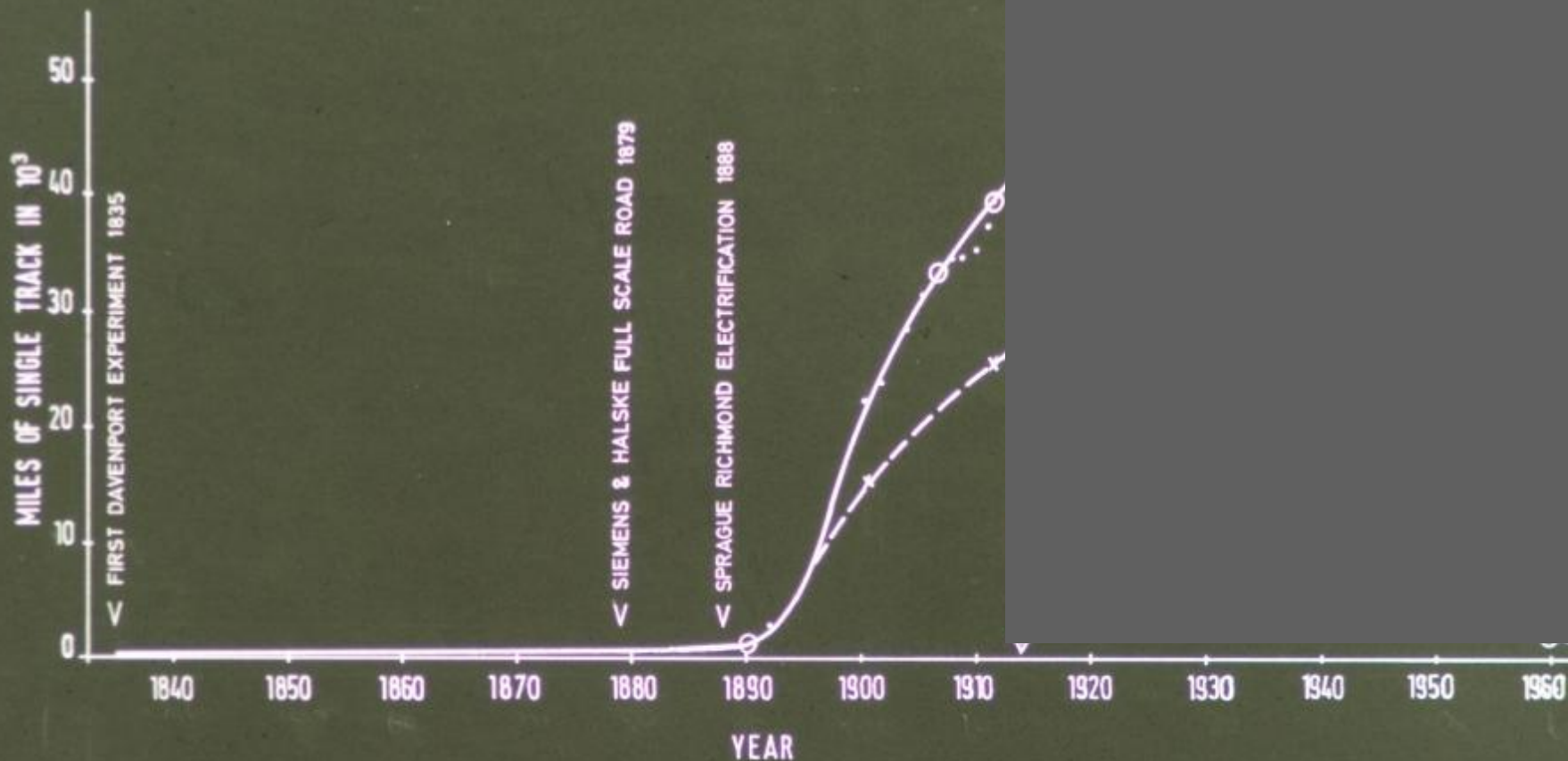





Witherspoon St.
@ Gate to Nassau Hall
Princeton, NJ, 1930





Build 'em Everywhere

Iowa

Indiana Ohio

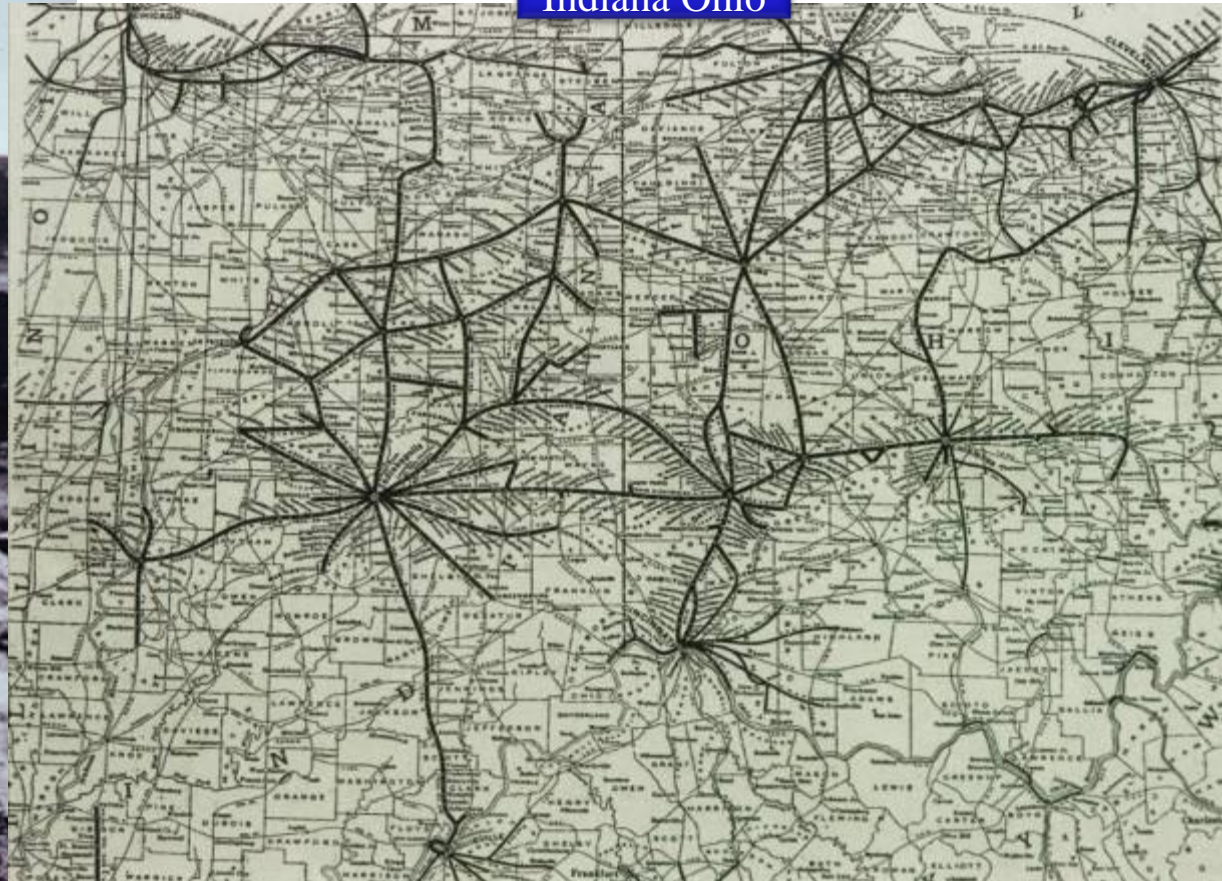
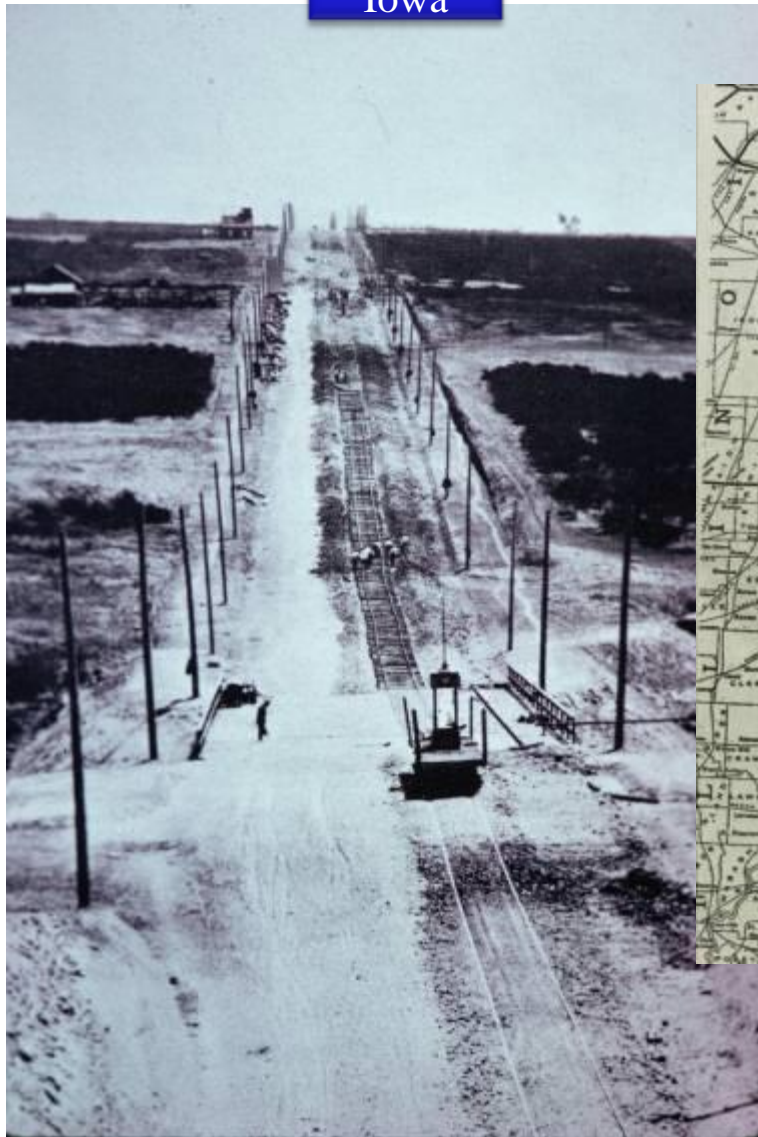



MAP OF THE PACIFIC ELECTRIC RAILWAY IN SOUTHERN CALIFORNIA



PACIFIC ELECTRIC RAILWAY
 WELLS-FARGO & CO. EXPRESS
WORLD'S GREATEST ELECTRIC RAILWAY SYSTEM

1000 Miles of Standard Trolley Lines
 To All Points of Greatest Interest in the Heart of SOUTHERN CALIFORNIA and Traversed by
2700 SCHEDULED TRAINS DAILY
 Including 5 Trains at Convenient Periods to

WORLD FAMOUS MOUNT LOWE
 A Climb from SEA LEVEL to CLOUDLAND
 By Trolley Through
 GREATEST SCENIC WONDERLAND





Putting the squeeze on the competition



But in the end....

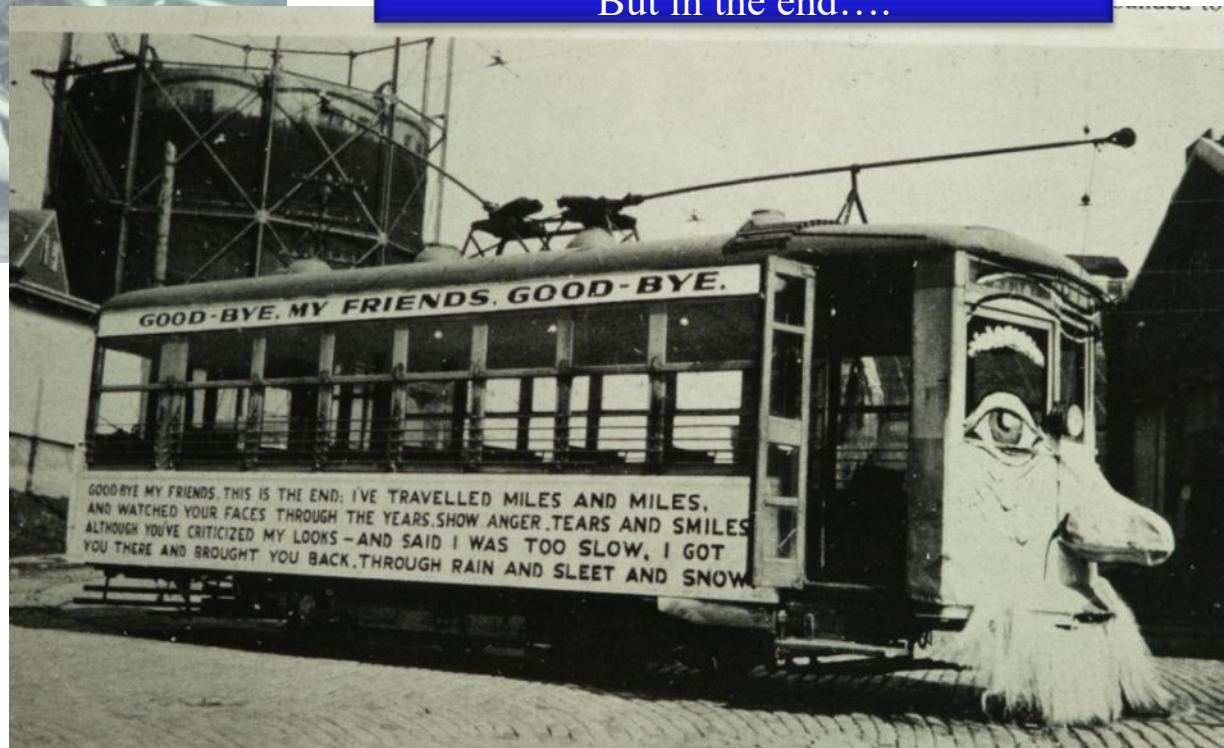

The lugubrious and whiskered Birney made its final trip in Halifax, Nova Scotia, in 1949. Seven years earlier the streetcar had carried some 32 million people annually.



Death of Electric Traction



*s lugubrious and whiskered Birney made its final trip in Halifax, Nova Scotia, in 1949. Seven years earlier the streetcar
hat city had carried some 32 million people annually*



Nostalgia of Electric Traction



Online sources of Light Rail Transit

- Replicas of Vintage Trolley Cars: John Smatlak [Link](#)
- Light Rail, Tramway and Urban Transit Links [Link](#)
- Light Rail Transit Systems in US [Link](#)

SF Muni



River Line NJ



Camden NJ
15 March 2004
© 2004 Jon Bell

Newark Subway



Newark NJ, July 2001
© 2001 Jon Bell



Growth to Maturity of Electric Traction

ELECTRIC RAILWAYS TRACKAGE 1888-PRESENT

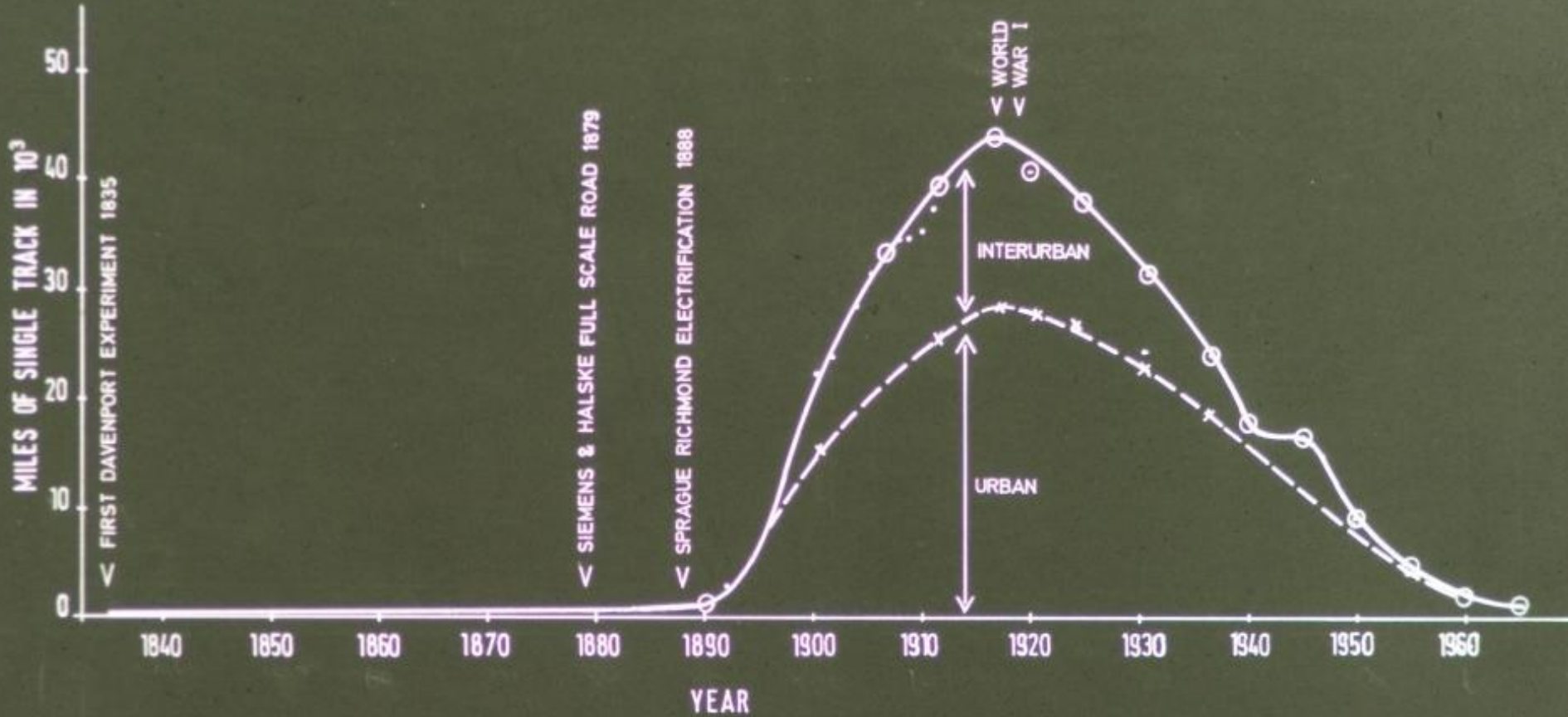

[Jon Bell's Rail Transit Pages](#)
Good source on many of his pictures and descriptions

Trolley Bus



1st Trolley Bus
Von Siemens
Kurfurstendamm St., 1879



LA, 1912



In 1912 this contraption ran in Laurel Canyon, Los Angeles.

Philadelphia, 1970



NYC 1930





Growth to Maturity of Electric Trolleys

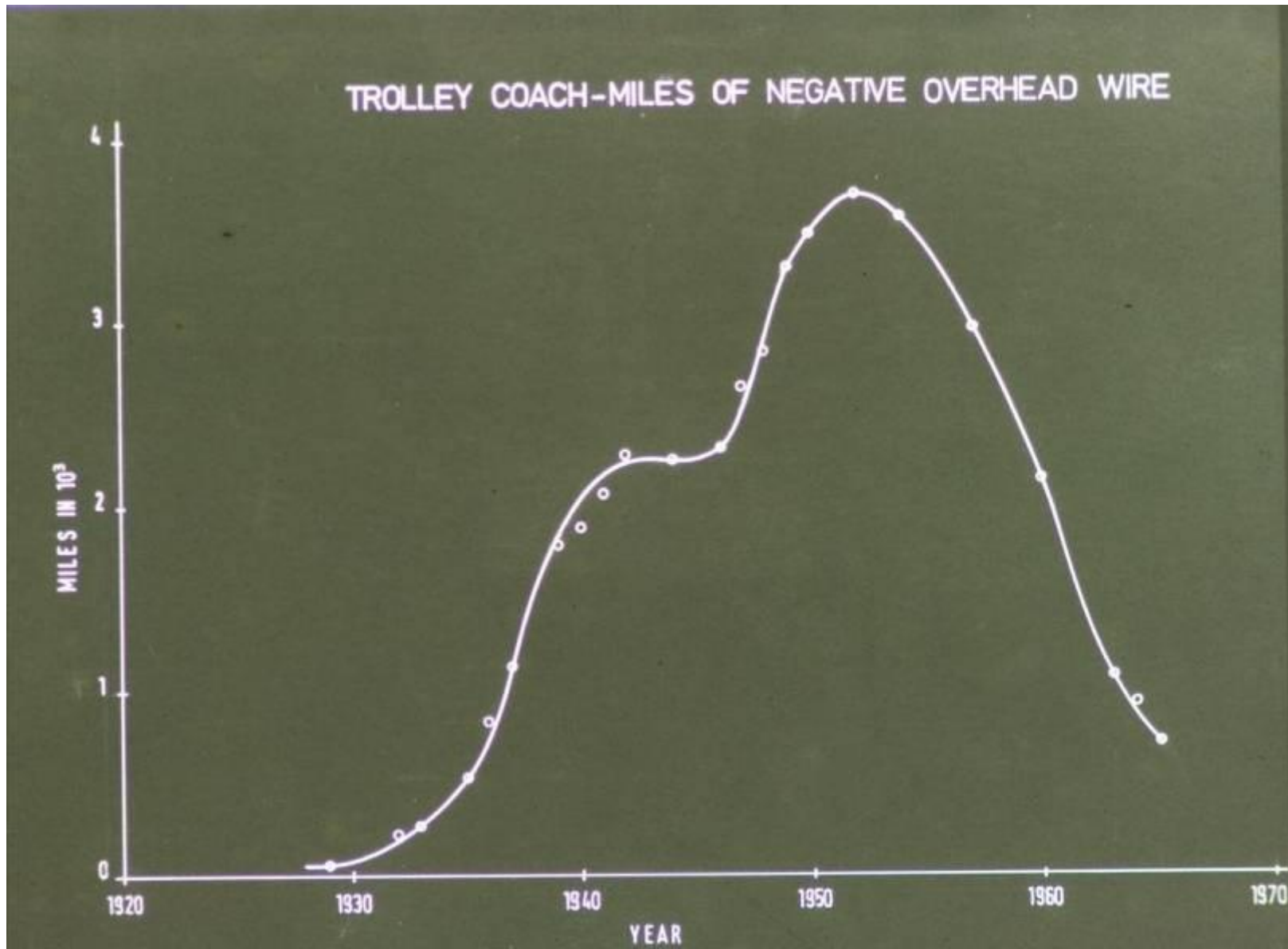



Early Innovators of the Automobile



Nicolaus Otto (1832-1891) invented the first practical alternative to the steam engine in 1876 -- the first four-stroke internal combustion engine. He called it the "Otto Cycle Engine," and as soon as he had completed his engine, he built it into a motorcycle.

Karl Benz 1844-1929



Benz patent 1886 1st Automobile

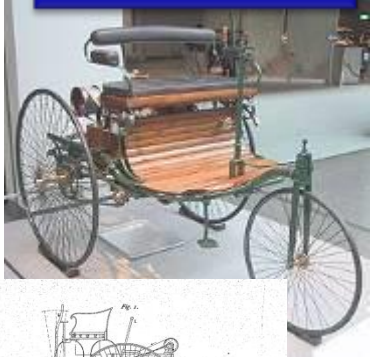

1st Production Benz, Velo, 1894

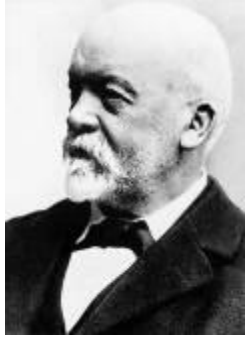

Gottlieb Daimler 1834-1900

Daimler Maybach Improved Otto's Engine
1st Motorcycle 1885; 4-wheel automobile 3/8/1886

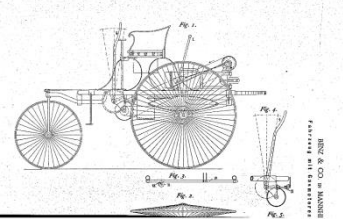

1st bus (modified Benz Truck) 1895



Wilhelm Maybach 1846-1929

Early Innovators of the Automobile Steam

Francis Edgar Stanley 1849 -1918
Freelan Oscar Stanley 1849 - 1940



1903 Mile Record

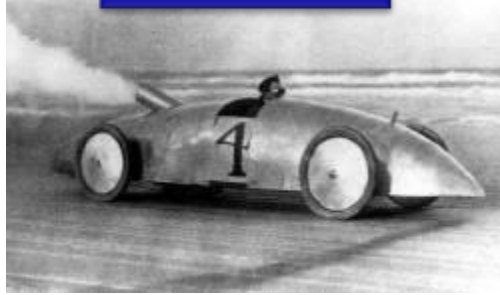

1908 Land Speed Record 127 mph



About Before the Accident.



Exaggerated View. Part of the Body of Rover After the Accident.
THE ACCIDENT TO THE STANLEY STEAM RACER CAR AT BIRMOY BRIDGE.

1918 Stanley Steamer



1913 Stanley Steamer





Early Innovators of the Automobile

Electric

History of Electric cars

1900 Baker Electric



GM ev1 2000



Crushed ev1s



Elon Musk to the rescue?



1905 Woods
Early electric cars

Who Killed the Electric car

Early Automobiles

Not so good!

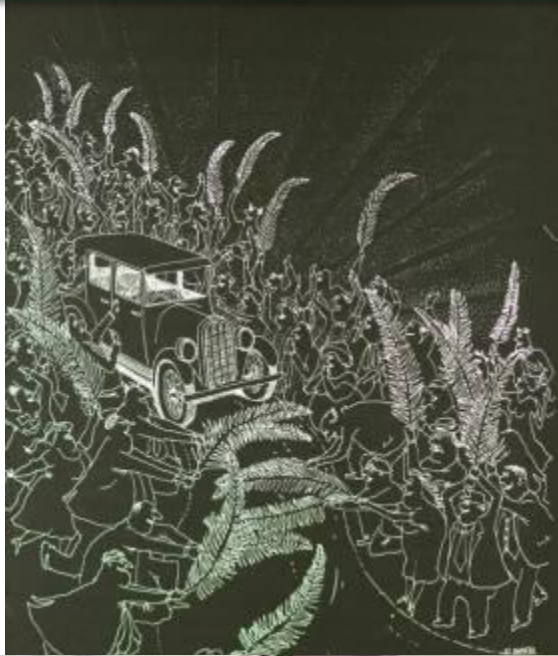

Bad Roads

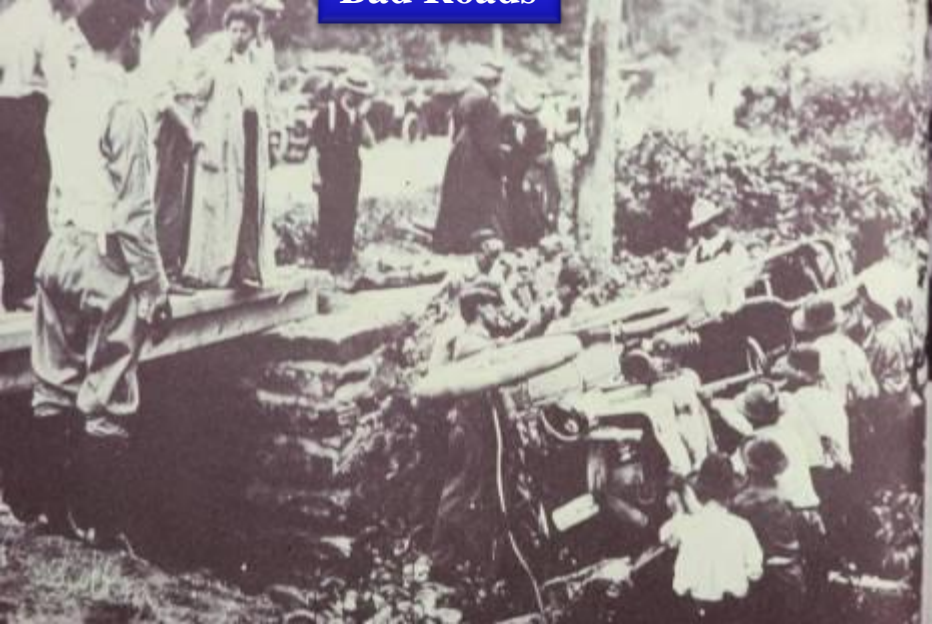

Bad Weather

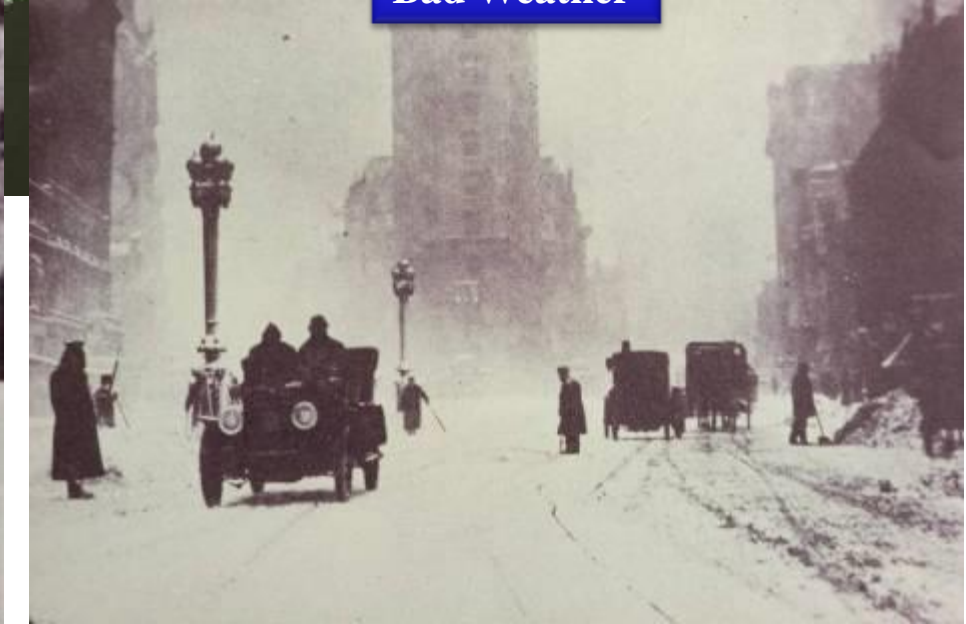



Dominance of Automobiles

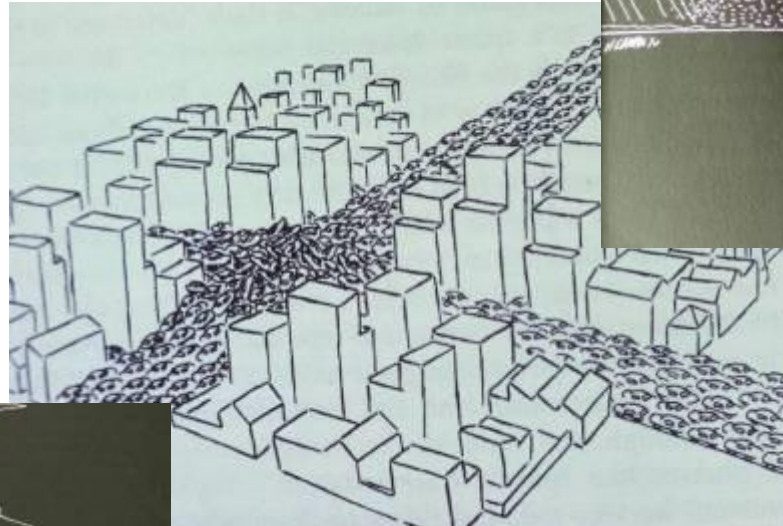



Dominance of Automobiles

US Automobile Registrations 1900-2005

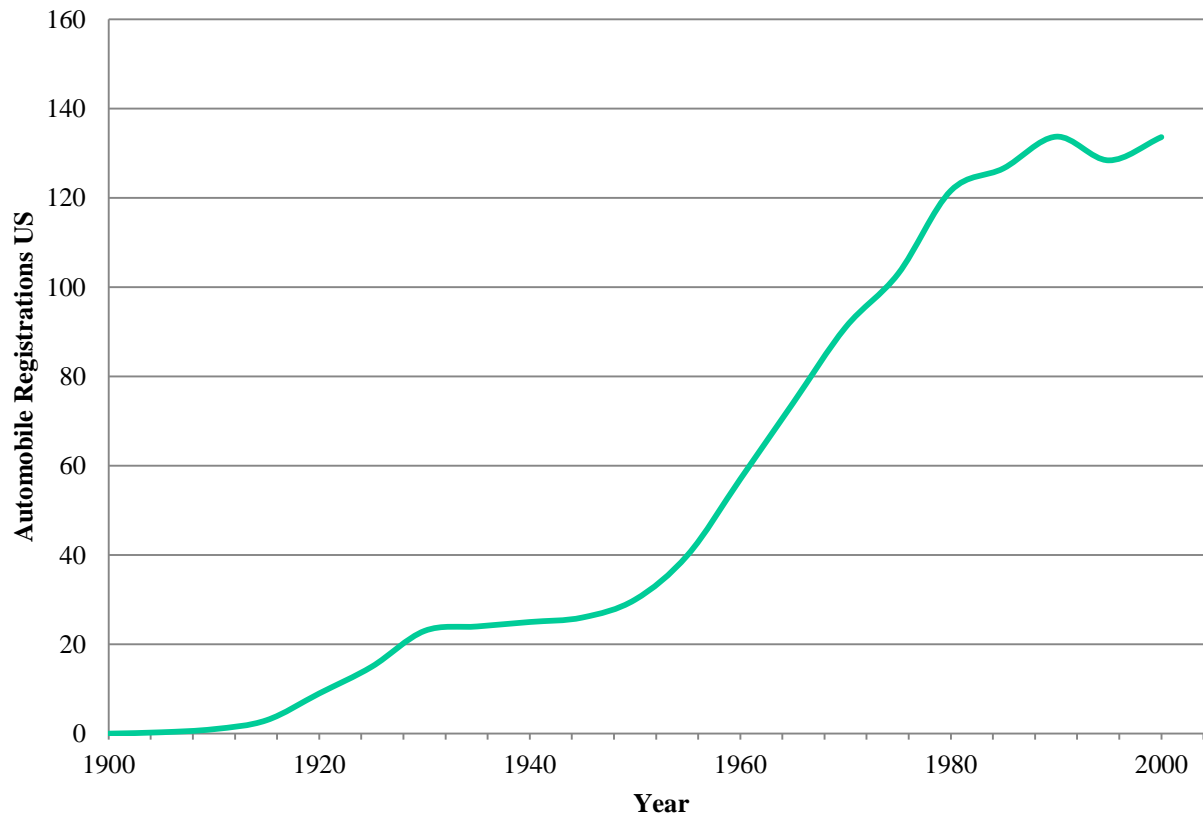



Innovative Solutions

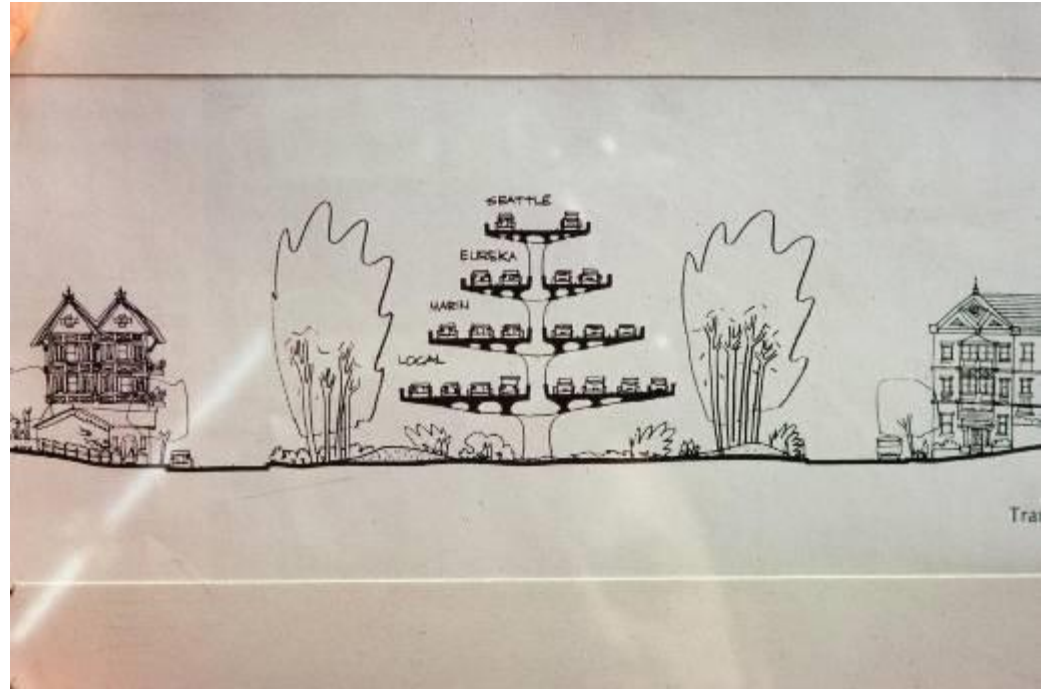



What about Mass Transit??

Do you mean Monorails??

MonoRails: Not a new concept Suspended

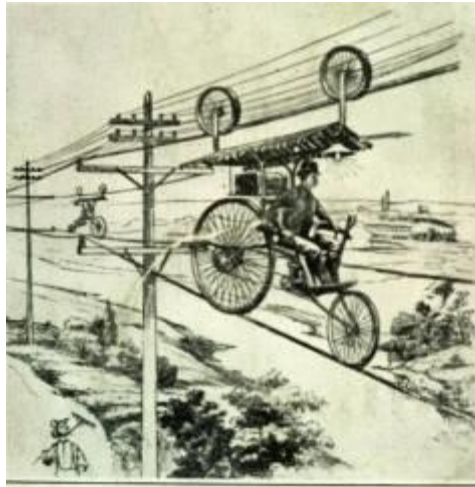
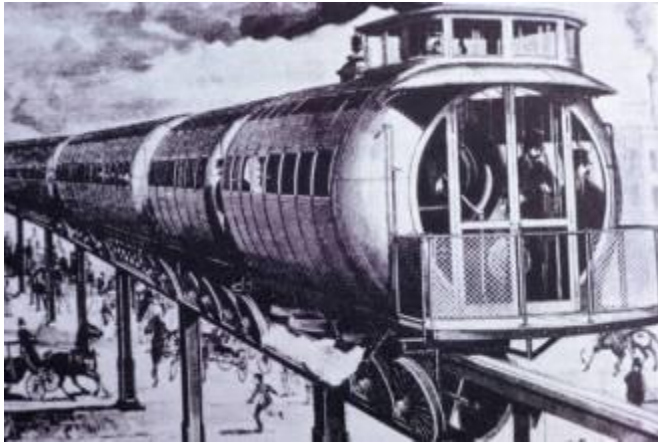

JS-Patent 1890



On the Right Track,

1886, Cambridge Line

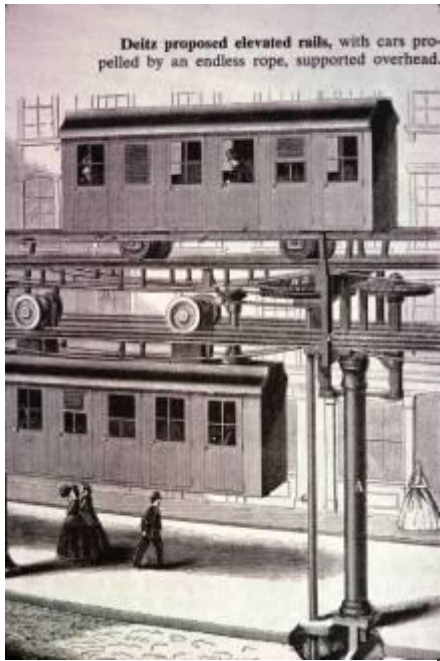

Deitz proposed elevated rails, with cars propelled by an endless rope, supported overhead.



End of a bright dream: a wrecking crew props up the toppled Pelham Bay monorail car. Note the single rail on the ground.

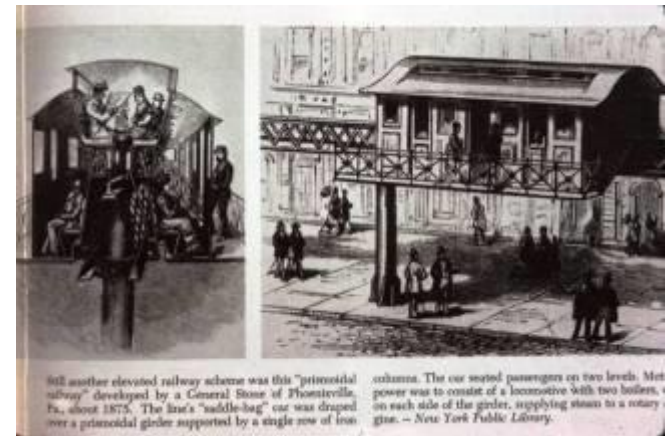

Still another elevated railway scheme was this "prismoidal subway" developed by a General Stone of Phoenixville, Pa., about 1875. The line's "saddle-bag" car was draped over a prismoidal glider supported by a single row of iron

columns. The car seated passengers on two levels. Mot power was to consist of a locomotive with two boilers, one on each side of the glider, supplying steam to a rotary engine. - New York Public Library.

Wuppertal Schwebebahn



- 8.3 miles
- 20 stations
- 22.9 M pax/yr
- 72,000 pax/day
- Av occupancy 52.8%
- 2.9 miles Av.Travel Distance
- .03632 kWh/pax

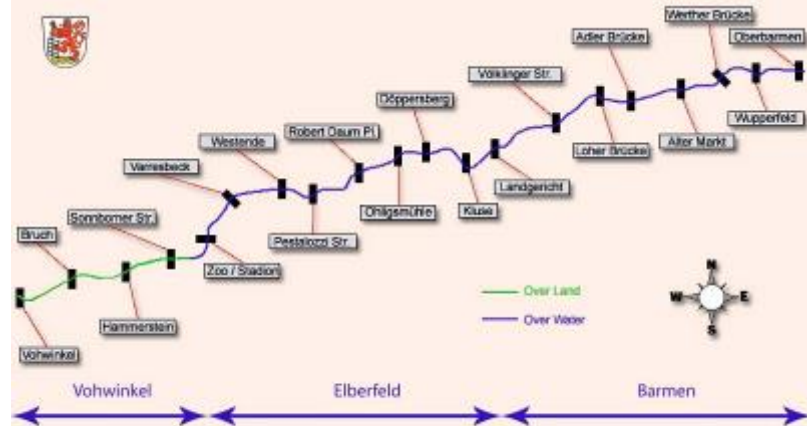

Movie

MonoRails: DisneyWorld



Alternative Propulsion:
You've got to go FAST!

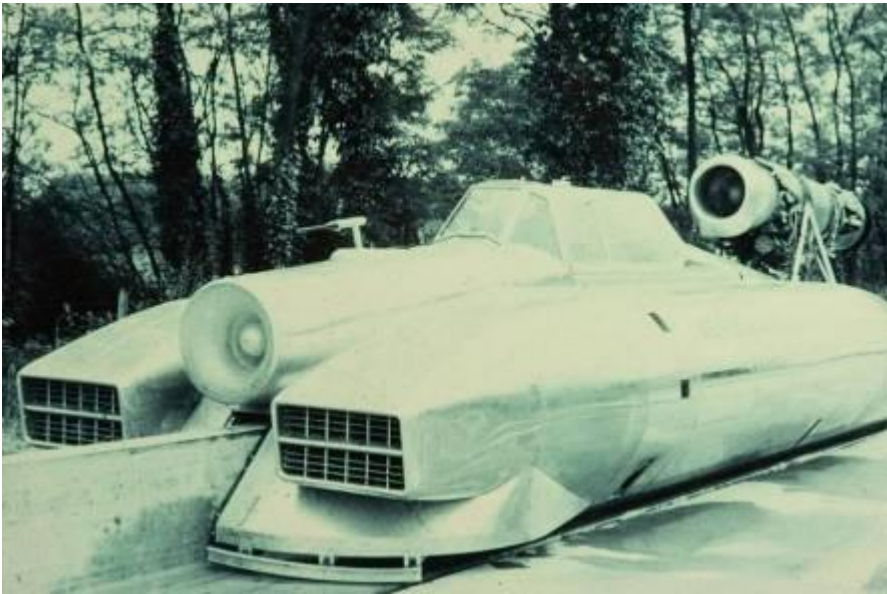

Automated Systems Commuter Rail



BART



Automated Systems Commuter Rail



Lindenwold NJ Line

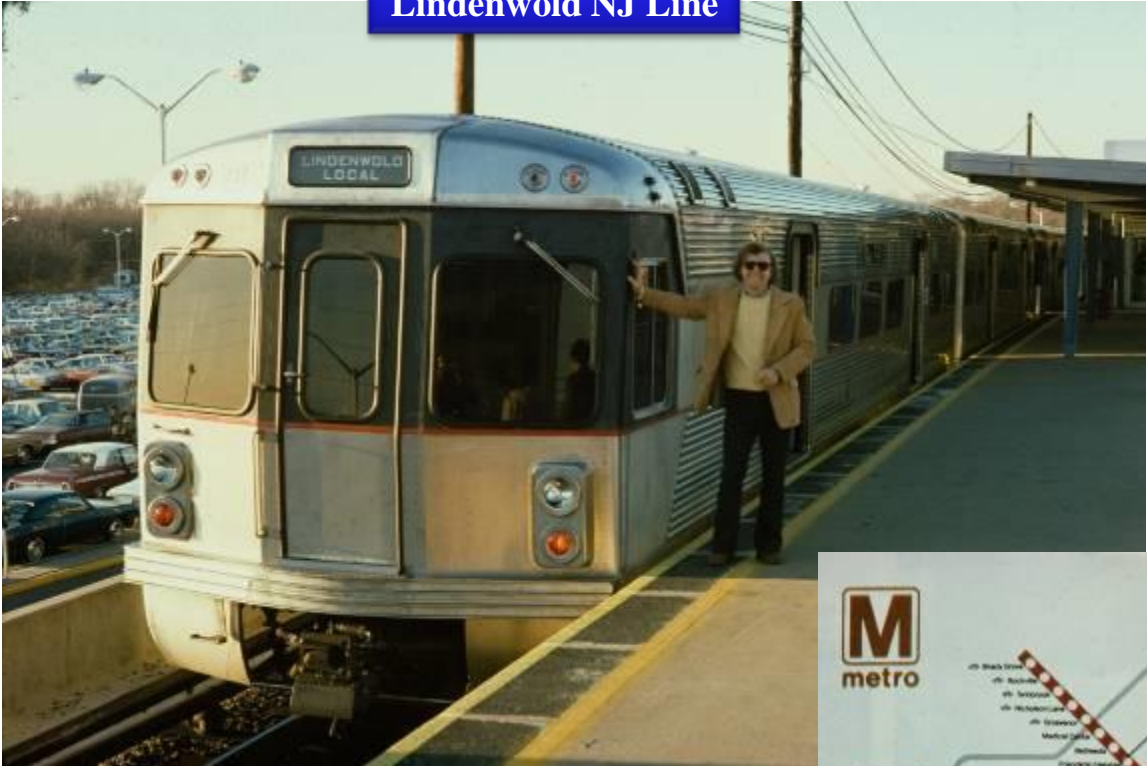

Automated People Movers



Westinghouse SkyBus,
South Park Test Track Pgh, Pa



Automated People Movers



**Westinghouse SkyBus,
South Park Test Track Pgh, Pa**



Tampa Airport



Starts with Alden Starr car



Morgantown PRT (On the vehicle switch!) (actually: Group Rapid transit (GRT))







Morgantown PRT

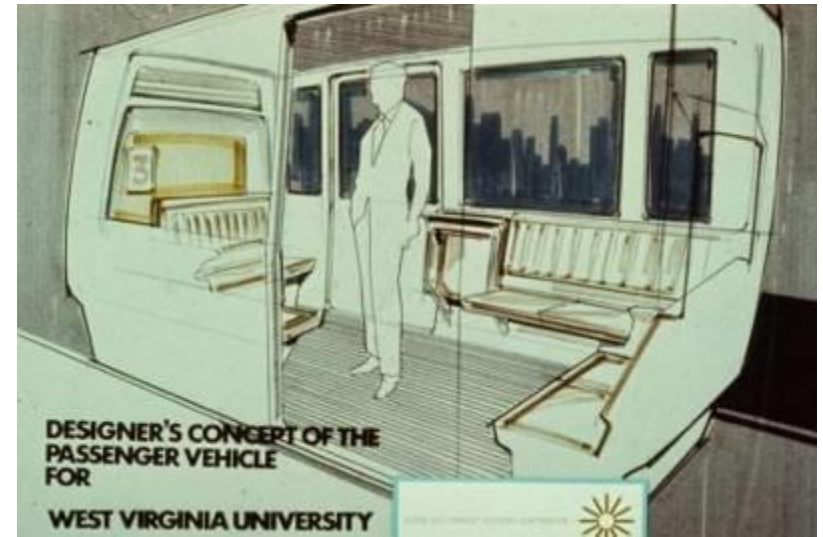



Morgantown PRT



Movie

Movie2

Morgantown PRT



DFW AirTrans PRT

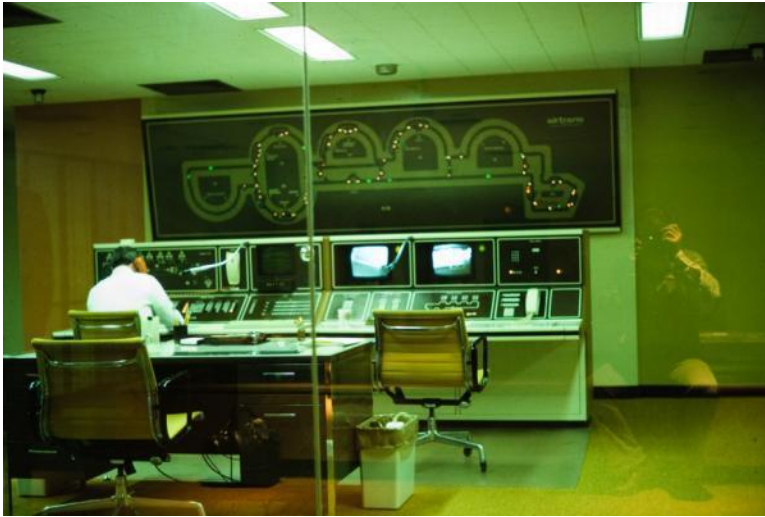

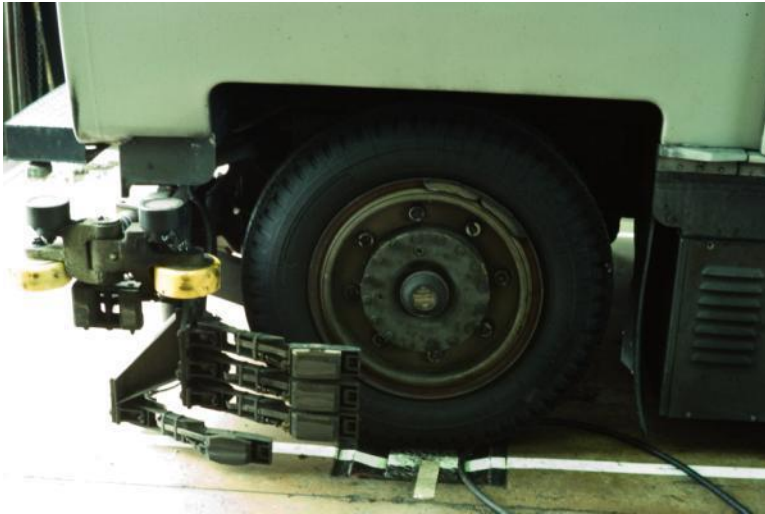

airtrans		VOUGHT
D/FW OPERATIONS AND MAINTENANCE STAFF		
MANAGEMENT AND ADMINISTRATION		3
PURCHASING AND SUPPLY		9
ENGINEERING		3
OPERATORS		11
MAINTENANCE		84
	TOTAL	110
AVERAGE STAFF ON DUTY DURING ANY SHIFT =		20
(24 TO 28 TRAINS IN OPERATION)		

Alternative Support Air Bearing



Transportation Technology, Inc. (TTI) -Otis

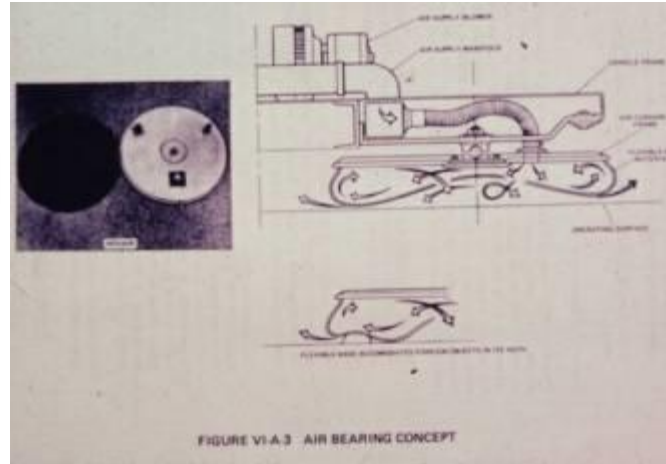

Compatible with:

- On-vehicle switch
- Linear induction propulsion
- Low Floor



Active element of LIM in guideway

Passive element of LIM in guideway

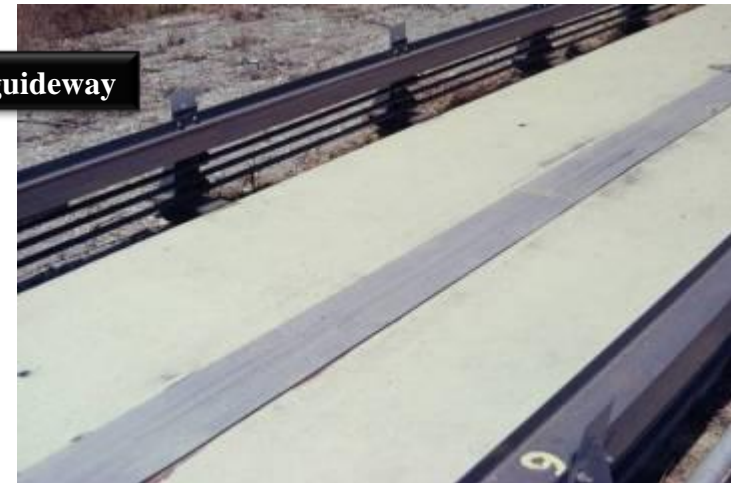

Alternative “Support”: Attractive Mag lev

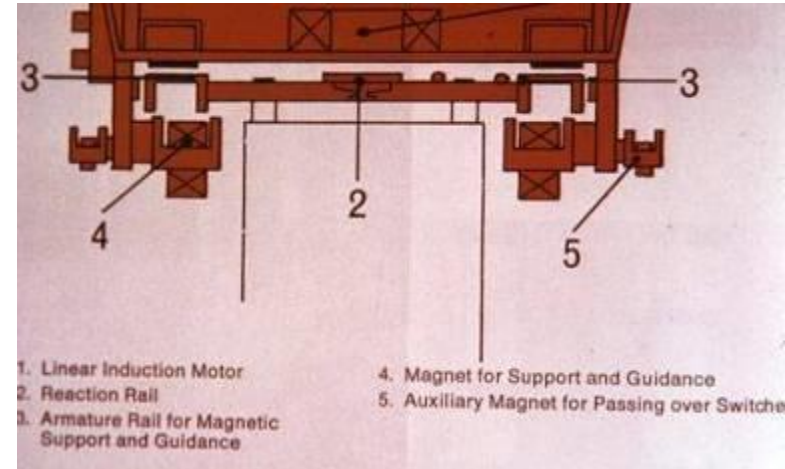

Alternative "Support": Overhead Suspended Rohr Monocab



s



Alternative “Support”: Overhead Suspended Rhor Monocab



Alternative "Support":
Overhead Suspended
Rhor Monocab



Alternative “Support”: Overhead Suspended H-Bahn

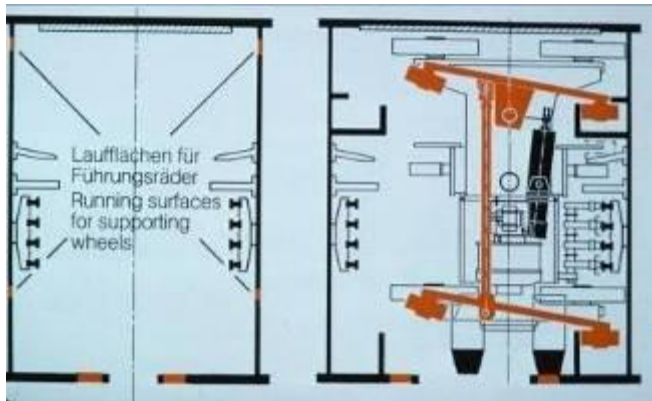
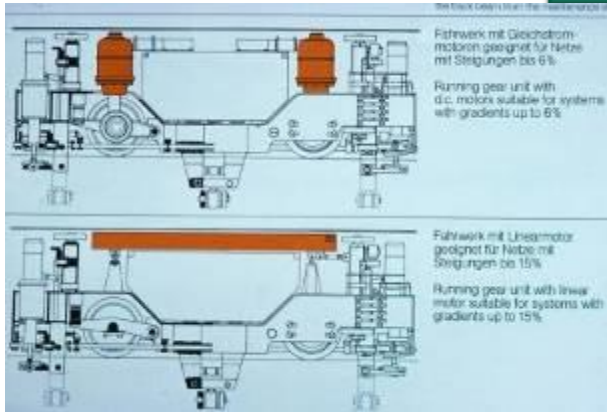



Alternative Headway Control

Laser range



Alternative Headway Control

Aramis



Alternative “Support”: “Both” CabinenTaxi

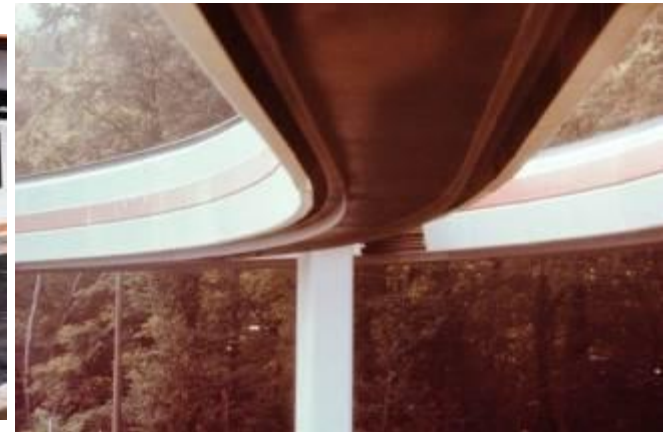

Alternative "Support": "Both" CabinenTaxi



Alternative “Support”: CVS

(Bullet through the propeller trick)



Alternative “Support”: CVS

(Bullet through the propeller trick)

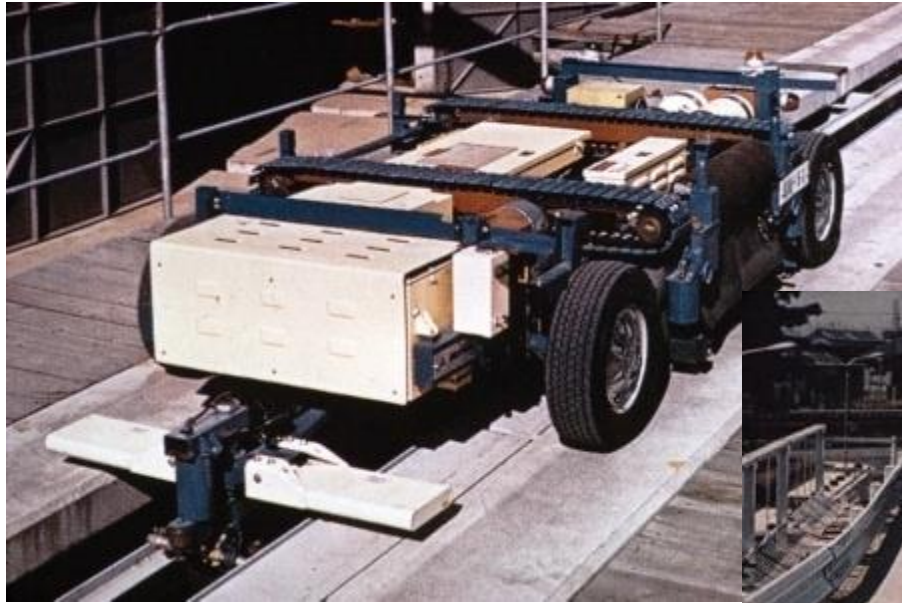



~40 years ago...

:

– Morgantown





Along the way...

Nothing much...

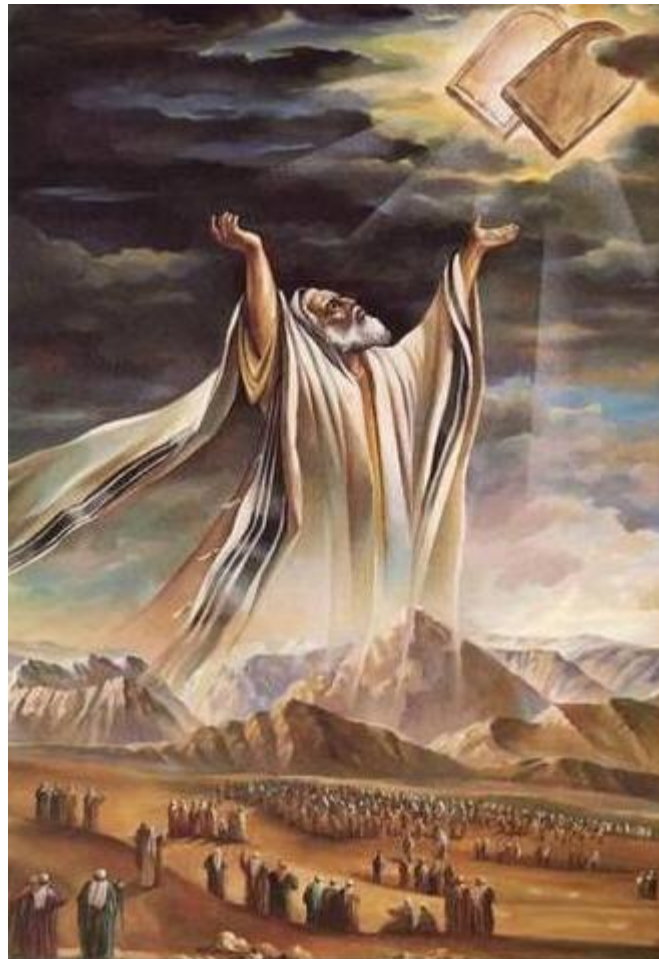



Current PRT Innovators: Vectus

[Link & Video](#)





And Today...

Masdar (2GetThere) & Heathrow (Ultra) are operational



[Video](#)



Today...

Morgantown 1975



Remains a critical mobility system today & planning an expansion





- PRT: Tough business case:
 - Segregated guideway too often needs to be elevated
 - Tends to pass by bedroom windows
 - Tough sell at public meetings
 - Guideway is Expensive
 - Small initial systems tend to be in areas of high demand
 - While a small vehicle system would work, so will a larger vehicle system, which has less risk
 - Example: airports, large APM (Automated People Mover) just fine even though they have no expansion potential (nor does the “owner” have expansion desires)
 - Therefore, not easy to get started.



- Automation of Road Vehicles
 - Automated Highways (1939 -> 1999)
 - Automated vehicles on exclusive automated highways
 - Tough business case:
 - » no one will build an automated highway if there are no cars to run on it
 - » No one will buy an automated car if it doesn't have any roads to run on
 - » (Henry Ford lobbied hard ([created a film & “propaganda” subsidiary](#)) to have “Farm2Market” roads built throughout the country so that buyers of his cars & trucks would have somewhere to drive them.
 - National Automated Highway System Research Program (1992~1997)
 - [National Automated Highway System Research Program A Review](#)
 - [AN OVERVIEW OF AUTOMATED HIGHWAY SYSTEMS \(AHS\) AND THE SOCIAL AND INSTITUTIONAL CHALLENGES THEY FACE](#)



- Automation of Road Vehicles
 - Concept of Automated Vehicles Sharing Roadways with Conventional Human-driven Vehicles (1994 ->)
 - I suggested the concept during the National Automated Highway System Research Program (1992~1997); however, it wasn't pursued.
 - Concept gained some traction during DARPA Challenges (2004,5,7)
 - Concept Propelled by Google's initiative to develop "Driverless-car" starting in 2010.
 - NHTSA "Automation "Levels"
 - (Level 0 (no automation) through Level 4 (driverless))
 - » Google: "Level 4" Product Market ready by 2018
 - » Nissan: 2 "Level 4" Models in showroom by 2020
 - » Volvo: Zero deaths by 2020
 - www.SmartDrivingCar.com

Princeton University
Orf 467 – Transportation System
Fall 2016/17

