

APPENDIX D

SUMMARY OF REMARKS
AT THE
AUTOMOBILE COLLISION DATA WORKSHOP

Lawrence Patrick
Wayne State University

January 16, 1975



WAYNE STATE UNIVERSITY

BIOMECHANICS RESEARCH CENTER
COLLEGE OF ENGINEERING
5050 ANTHONY WAYNE DRIVE

DETROIT, MICHIGAN 48202
TELEPHONE: (313) 577-3835

January 20, 1975

Mr. Howard Gates
Economics & Science Planning
1200 18th Street
N.W. Washington, D.C. 20036

SUBJECT: ESP Meeting, January 16 & 17, 1975

Dear Mr. Gates:

As requested at the captioned meeting, I am enclosing herewith prints of the slides I used in my presentation together with a brief summary of my remarks. In the interest of brevity, the remarks are presented in outline form.

PREMISE

1. The only valid way to establish safety needs for automobiles is through examination of field data.
2. The only valid way to evaluate the effectiveness of safety measures is through analysis of their effect on accident data.

CONCLUSION

Accident data are essential.

CRITERIA FOR DATA COLLECTION

1. Sufficient data must be obtained for statistical analysis. Collection of accident data is expensive so it must be optimized for the number of variables, depth of study, and type of collision to minimize the cost per accident. The present MDAI studies cost approximately \$2500.00 apiece, and include greater detail than is necessary. With modification of the collection procedure accident data in sufficient depth should be available at a cost of under \$400.00 per case. Other data should be gathered on a large sample basis in even less detail at a considerably lower cost.
2. Complete injury data must be included in the accident data. Sex, age, weight, height, and general physical condition are all important factors in analyzing accident data. The type and degree of injury of each occupant including the minor bruises and abrasions and going through the severe bone and soft tissue damage are required. It is important to have complete data on the restraint systems used and the interior components of the vehicle that caused the injury.

Mr. Howard Gates
Economic & Science Planning
January 20, 1975

3. Complete vehicle crash data are essential to permit an estimate of the collision severity. The crash data in addition to the usual photograph should include measurements of vehicle deformation. A standard means of recording deformation of the vehicle would be beneficial.

4. Reference collisions are required to establish severity of the accident from the crash data and deformation measurements. Eventually the reference collisions and deformation data can probably be replaced by a data recorder. The data recorder should be relatively simple and the cost should be low enough to permit installation in all vehicles. A crash severity signature is required which gives crash severity in the most meaningful terms. This does not necessarily require triaxial acceleration time histories. The Barrier Equivalent Velocity that has been used extensively is not necessarily the best measure of severity, but is one that has been used extensively and should continue to be used until a better measure of severity is developed.

DATA ANALYSIS

1. Standardized injury and deformation reporting is essential to keep the results of investigations by different groups in different parts of the country on a uniform basis. The AIS scale and the VDI should be considered for the immediate future and utilized until a better scale is devised.

2. The effect of sex, age, weight, size, position in vehicle, direction of impact, restraint systems etc. should be established. This will permit an accurate judgement to be made of the area of safety improvement that should be stressed.

3. Probability of injury as a function of collision severity is essential. It should be recognized that some individuals are going to be injured severely at low severity due to inherent weaknesses. Fundamentally, it is necessary to protect the maximum number of people from the maximum number of exposures. From a design standpoint, it is essential to establish an acceptable degree of injury under the most severe collision conditions. It is recommended that the AIS-3 injury be the maximum acceptable injury with no injury as the ultimate goal.

EXAMPLE: WSU-VOLVO STUDY

1. The WSU-VOLVO study was divided into four major divisions as follows:

- a. Accident Investigation - complete injury data including the AIS rating and complete vehicle deformation measurements.

Mr. Howard Gates
Economic & Science Planning
January 20, 1975

- b. Staged Collisions - complete deformation data in terms of impact speed.
- co Simulation Tests - records of injury criteria as a function of simulated speed.
- d. Analysis - Injury data related to severity and test data.

The accident investigation was conducted by the Volvo investigation team with special instructions to meet the requirements of this study. The staged collisions included frontal force, barrier, pole, and car to car collision. The collision simulations were made in the laboratory in a modified Volvo automobile with instrumented dummies as the occupants using the same stopping distance and deceleration pulse as measured from the staged collisions.

2. Accident criteria established to minimize the number of variables include:

- a. Frontal force collisions only.
- b. Belted front seat occupants (one or more).
- c. No unbelted rear seat passengers or other heavy objects in the rear seat.
- d. No external secondary impact of substantial severity.

3. With these stipulations, a total of 128 accidents were investigated with 169 occupants in a two year period. During this time there were eleven staged collisions at Volvo and 72 simulated tests at Wayne.

4. Figure 1 is a plot of the injury as a function of Barrier Equivalent Velocity with three injury areas for each occupant. As noted from the legend, the data are divided into head, neck, and chest injuries for each occupant with the driver and right front passenger position differentiated. The figures at the bottom of the graph refer to the number of body areas at each velocity for which there were no injuries. It is important to note that AIS-3 injuries were found at velocities ranging from 10 to 53 mph with the major number clustered at about 30 mph.

Figure 2 is a bar graph showing the distribution of injury as a percent of the number of occupants in 10 mph increments. At the 0 to 9 mph level approximately 90% of the occupants had no injury and the remaining 10% sustained only minor injuries. In the 50 to 59 mph range all occupants had some injury with one third having the AIS-1 injury and two thirds having AIS-3 injury. It is obvious that as the BEV increases the injury also increases.

Mr. Howard Gates
Economic & Science Planning
January 20, 1975

Figure 3 is a sketch of the rib cage with rib fractures and sternum fractures illustrated. In the field study all of the rib fractures occurred on the inboard side which is the side which the belt applies the force to the ribs. The fractures have all been put on one side although in the field there were fractures to the driver and passenger and consequently they were on both the left and the right side of the rib cage.

5. The accident investigating team carefully measured the deformation of the vehicle at six different points on the front as shown in Figure 4. A computer program was developed to record the six deformation measurements in graphical form. Figure 5 shows the deformation for the staged barrier collisions. These were all normal frontal force collisions and consequently the deformation is symmetrical. Figure 6 shows the same data obtained from the measuring fixture in the field accident study. It will be noted that in this figure the impacts are to poles and/or asymmetrical impacts which result in a different pattern than the barrier results. It was necessary to interpolate the field data to provide the closest BEV for the analysis. It is felt that the overall barrier equivalent velocity assigned to each collision is considerably more representative of the collision severity than in previous studies.

6. Figure 7 shows the rib fractures for male and female as a function of velocity. It should be noted that the age of the occupant should be included as another variable. However, the figure shows that the female has a greater number of ribs fractured than the male.

7. Figure 8 is a graph of cumulative injury risk as a function of abbreviated injury scale with velocity as a parameter. The data are plotted for the 10 mph increments. The dash lines indicate that the data are extrapolated with insufficient data for an exact definition of the curve. However, the data show a distinct family of curves. Additional data is required to delineate the curves with greater accuracy. The same data are shown in Figure 9 with abbreviated injury as a function of barrier equivalent velocity. This graph permits an estimate of the likelihood of injury in a given frontal force collision.

AMOUNT OF DATA REQUIRED

1. The collection of accident data requires a substantial amount of data with extreme accuracy desirable but not necessary. For example, there is no need to have a collision severity to within plus or minus "one mile per hour". This is especially true since we really don't know what the barrier equivalent velocity means or whether some completely different severity index should be used. With the large number of variables including impact velocity, impact direction, rigidity of vehicle, rigidity of object struck, location of impact on car, occupant location, occupant age, sex, height, weight, physical condition, tolerance

Mr. Howard Gates
Economic & Science Planning
January 20, 1975

to acceleration environment, posture, vehicle interior design, and restraint systems, it is more important to have a substantial amount of data with reasonable detail rather than a small number of cases that have been investigated to a great depth.

2. With the large number of variables it is necessary to have a large number of recorders in the vehicle population in order to obtain a reasonable number of accidents with the recorders in the car. The most desirable situation is one in which each car manufactured is equipped with a recorder installed at the factory.

CRASH RECORDER REQUIREMENTS

1. The crash recorder should be installed in a large number of vehicles. Consequently, it must be low in cost.

2. The recorder does not have to be ultra-accurate (such as plus and minus one percent on the acceleration and time scale), since the analysis will be based on a large amount of data rather than a small sample which would require the greater accuracy.

3. The crash recorder should be based upon a "severity index" that has yet to be developed depending upon the injury potential to the occupants. Such a recorder could be an integrating accelerometer with electronics to perform necessary operations on the accelerometer output to provide the severity index. Other means that might be satisfactory include fracture of a number of elements in the accelerometer or the deformation of an element in the accelerometer. The exact function to be measured and the method of measuring it has to be developed.

4. The crash recorder should be developed in conjunction with the data analysis group to insure maximum utility from the installation of the recorder.

5. The recorder should be sealed to prevent tampering and to guarantee that when the record is interpreted it has not been damaged prior to being collected by the investigator. It should be designed to give a record for a collision in excess of some predetermined severity such as a 10 mph barrier equivalent or greater. This will avoid the danger of having a recorder in multiple crashes which could confuse the data or give false results. Obviously the recorder must be rugged enough to withstand the collision without damage.

I believe that you or Dr. Goldmuntz requested a copy of my curriculum vitae and list of publications. They are enclosed.

I thoroughly enjoyed the meeting on January 16th and 17th and feel that it was productive in that I learned considerably from it. Hopefully, the goals of the meeting will be achieved. Bob Cromack has the preliminary writeup that we came up with during our working

Mr. Howard Gates
Economic & Science Planning
January 20, 1975

lunch on Friday. He is going to have it typed up and sent to the rest of us (Brian O'Neill and David Morganstein). We will review it and approve or modify it for final submission.

An invoice for my expenses is enclosed in accordance with our agreement.

It was a pleasure to work with you on this program. If I can be of any further assistance, please don't hesitate to call on me.

Sincerely,

A handwritten signature in black ink, appearing to read "L. M. Patrick". The signature is written in a cursive style with a large initial "L" and "P".

L. M. Patrick
Professor

LMP:ldd
ENCLOSURE

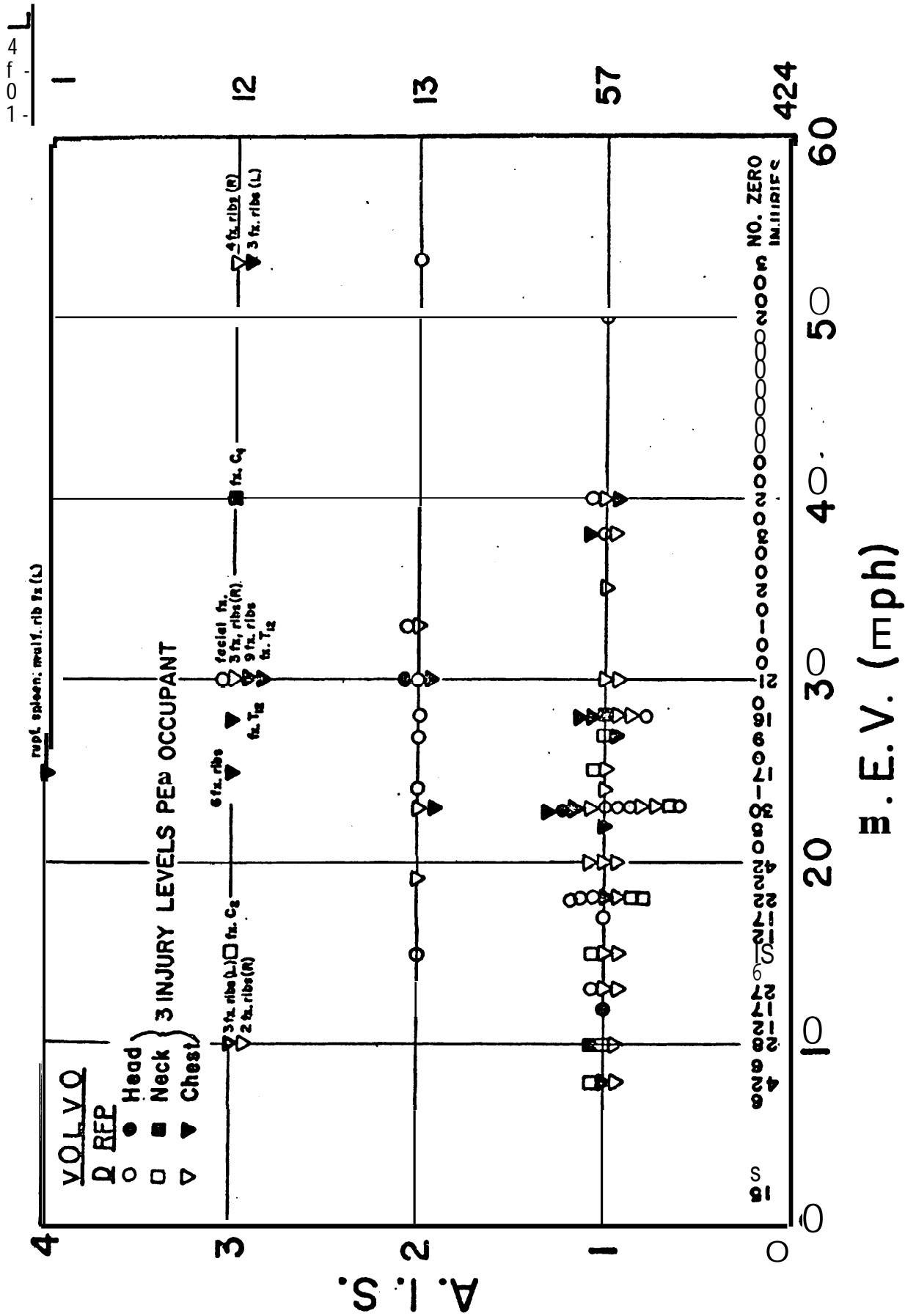
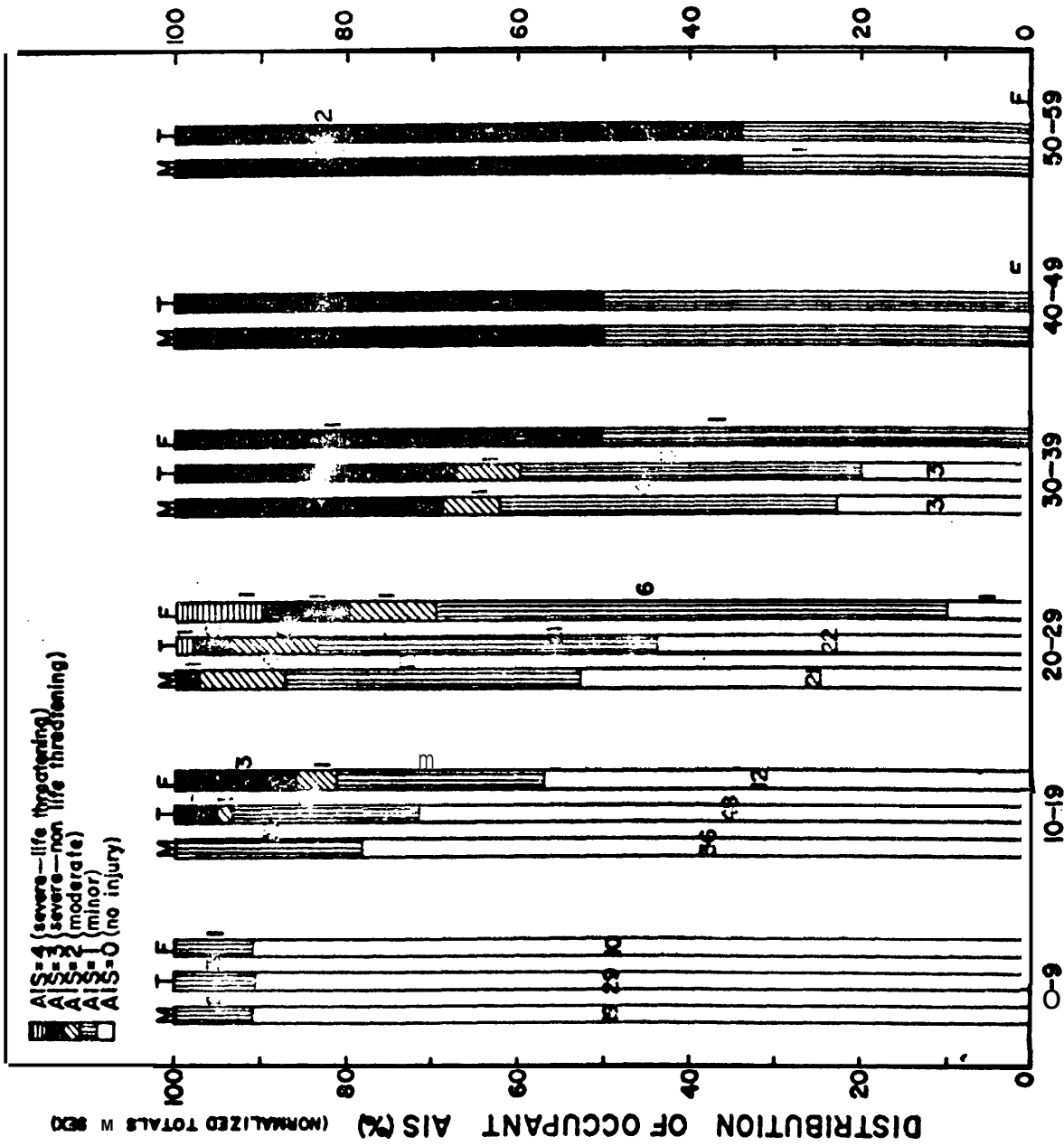

FIGURE 1: ACCIDENT INJURIES IN TERMS OF AIS AS A FUNCTION OF BARRIER EQUIVALENT VELOCITY WITH THE MOST SEVERE INJURY TO HEAD, NECK, AND CHEST INCLUDED.



B. \leq V. (mph)

FIGURE 2: DISTRIBUTION OF SINGLE MOST SEVERE OCCUPANT INJURY (AIS) NORMALIZED BY CATEGORY FOR EACH VELOCITY INCREMENT

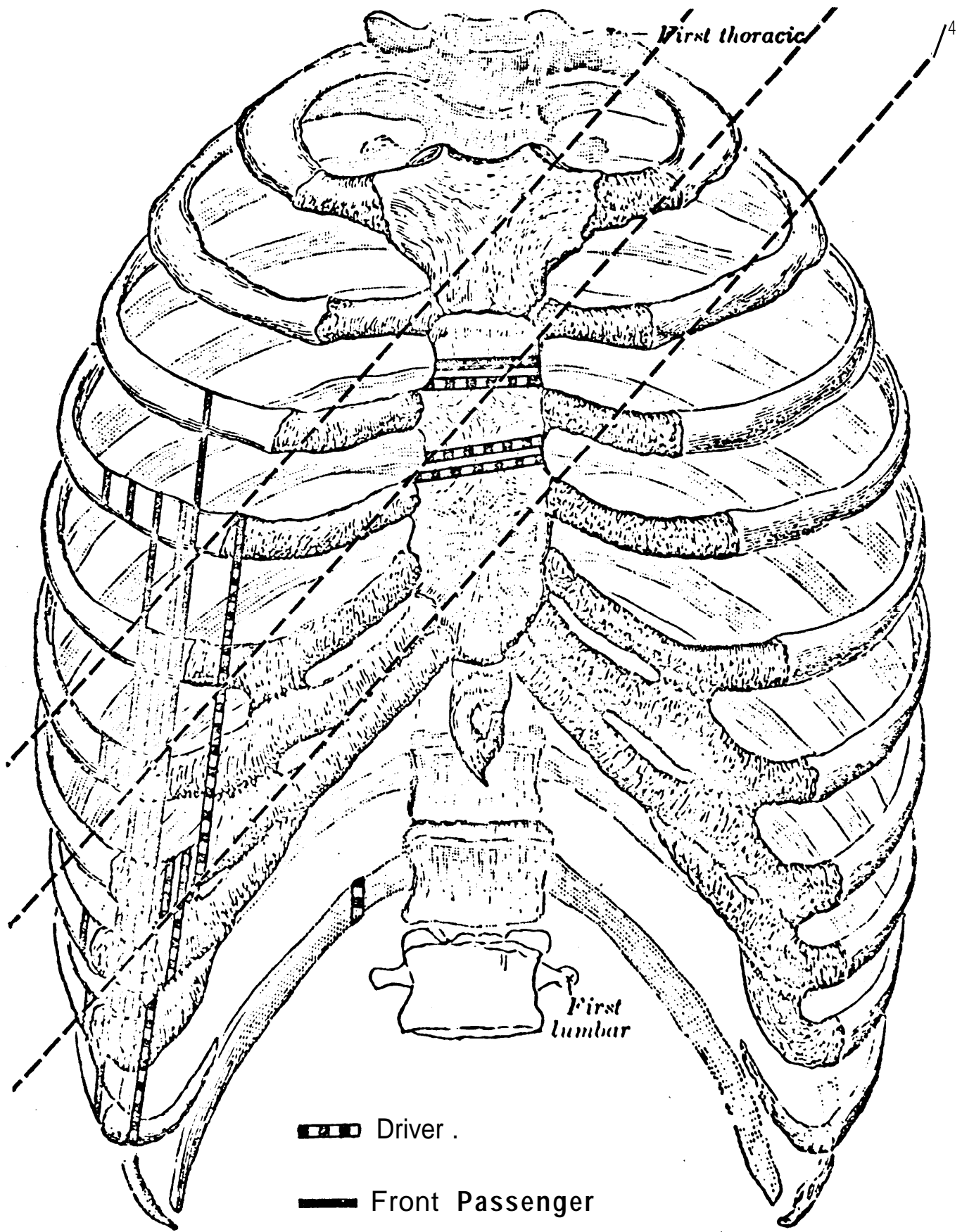
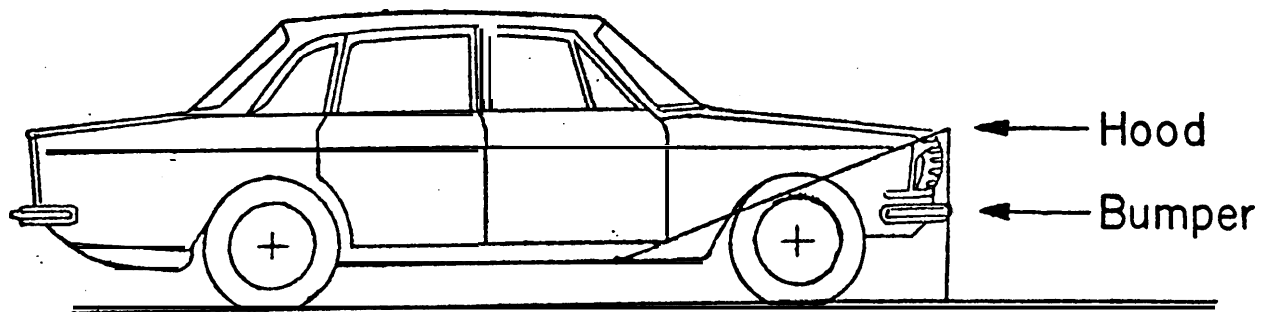

FIG. 3: ALL RIB AND STERNAL FRACTURES (WITH PASSENGER INJURIES TRANSFERRED TO THE DRIVER'S SIDE)

Vertical



Horizontal

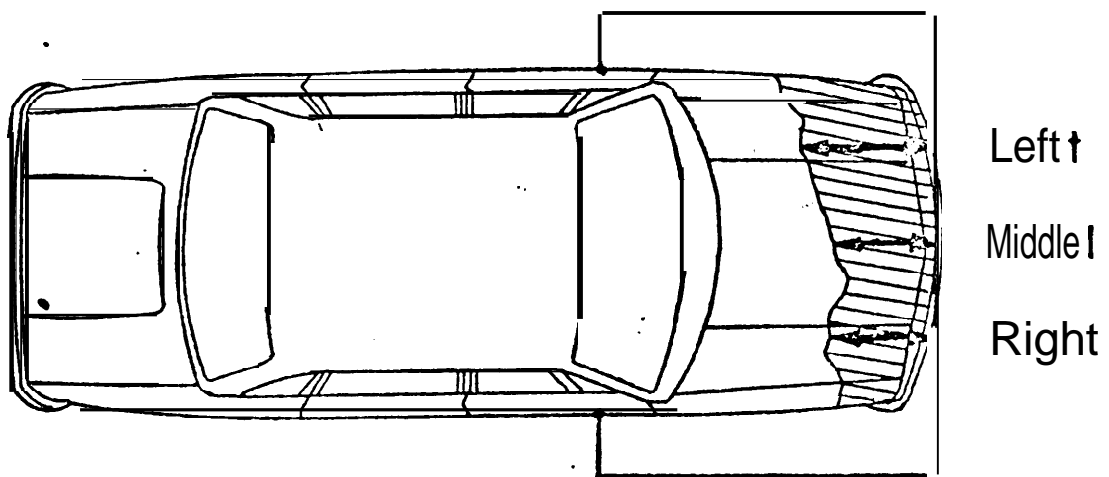

FIGURE 4 : DIAGRAM SHOWING MEASUREMENTS TAKEN WITH FRONT END DEFORMATION FIXTURE.

VOLVO TEST VEHICLES

20, 30 AND 50 MPH BARRIER COLLISION

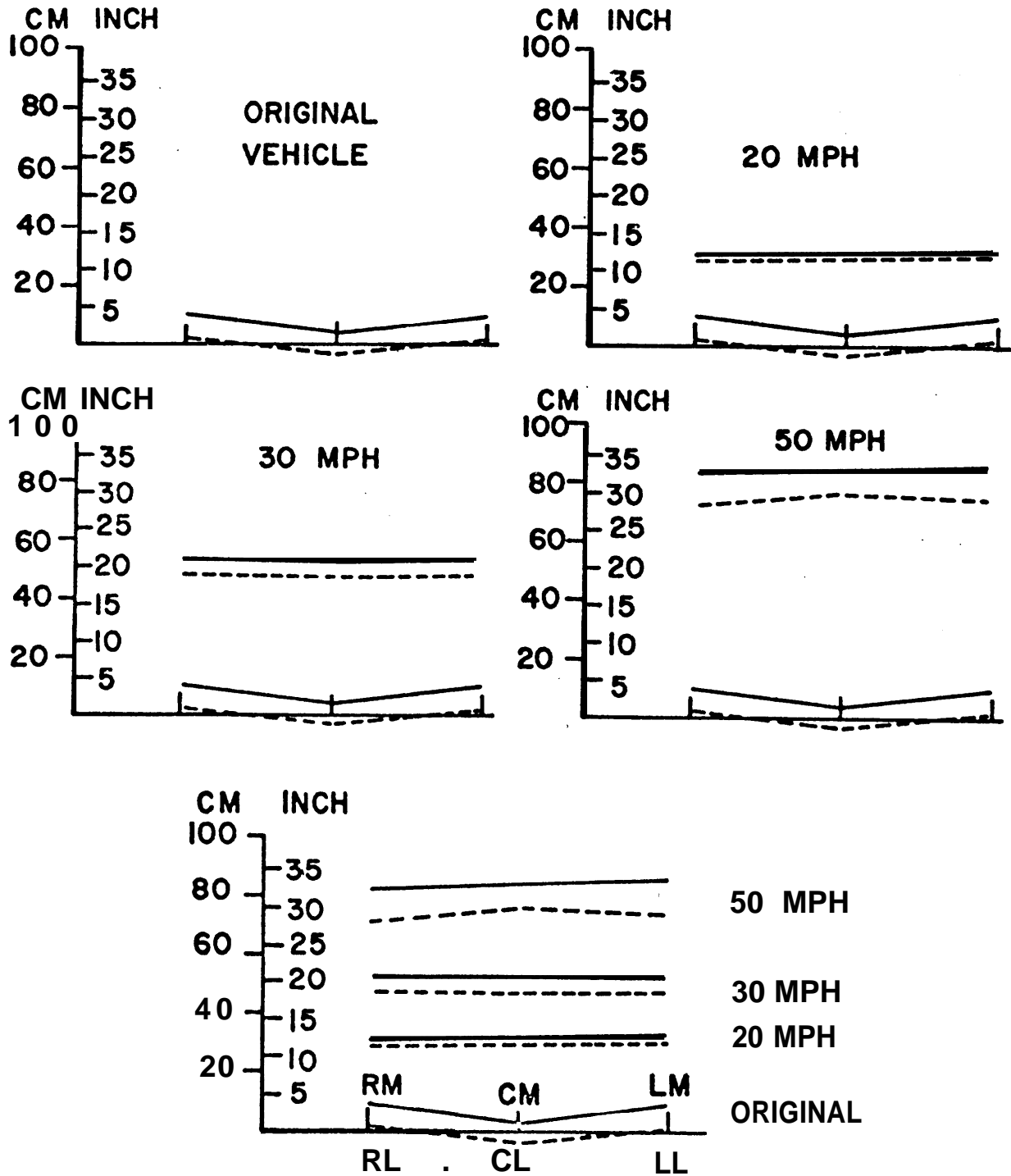

FIGURE 5: HOOD AND BUMPER DEFORMATION FROM STAGED FRONTAL BARRIER COLLISIONS.

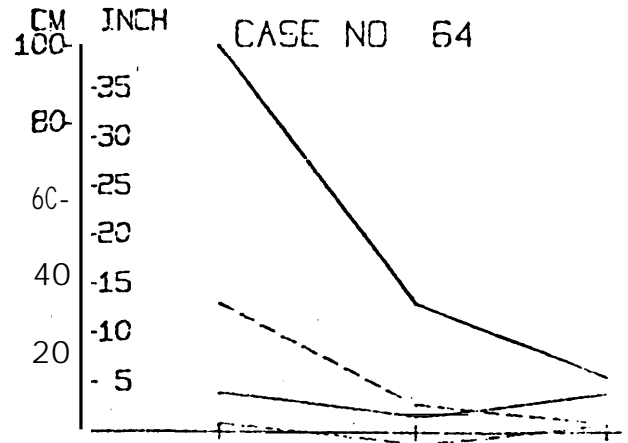
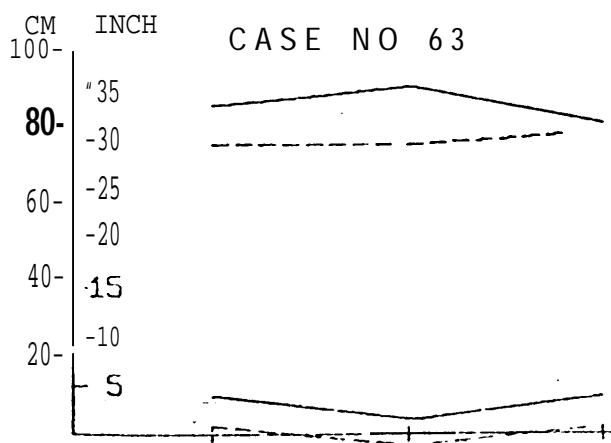
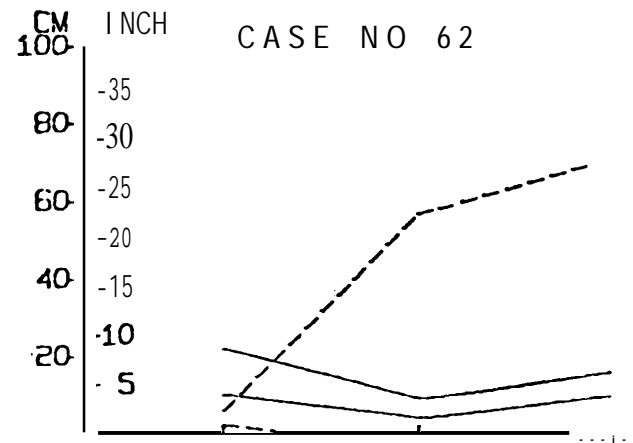
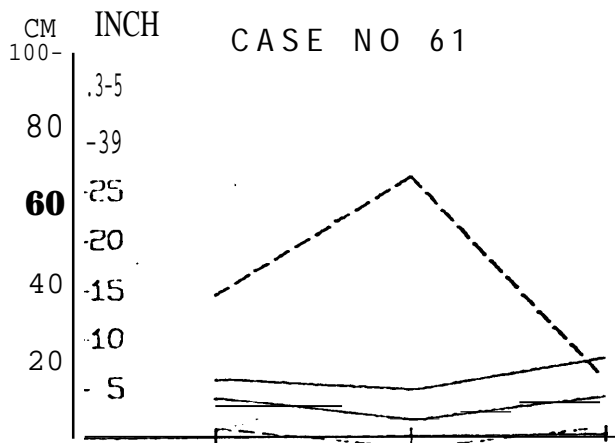
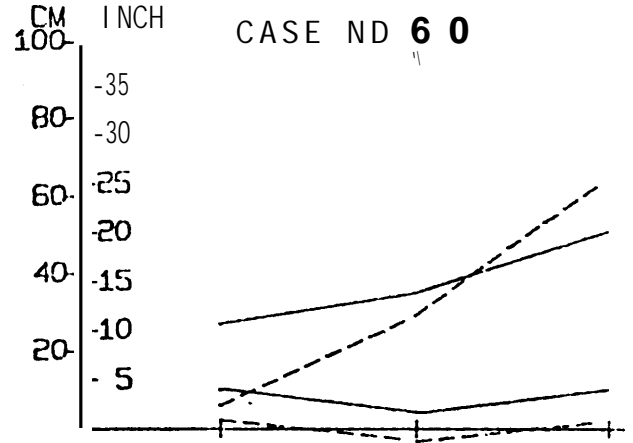
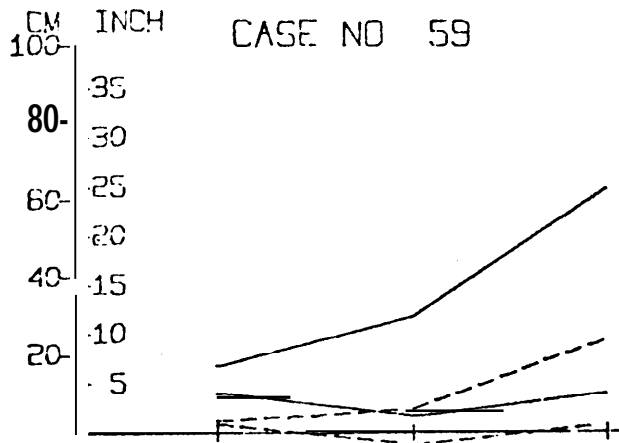

FIGURE 6 : " DEFORMATION DATA FROM EIGHT OF THE ACCIDENT CASES .

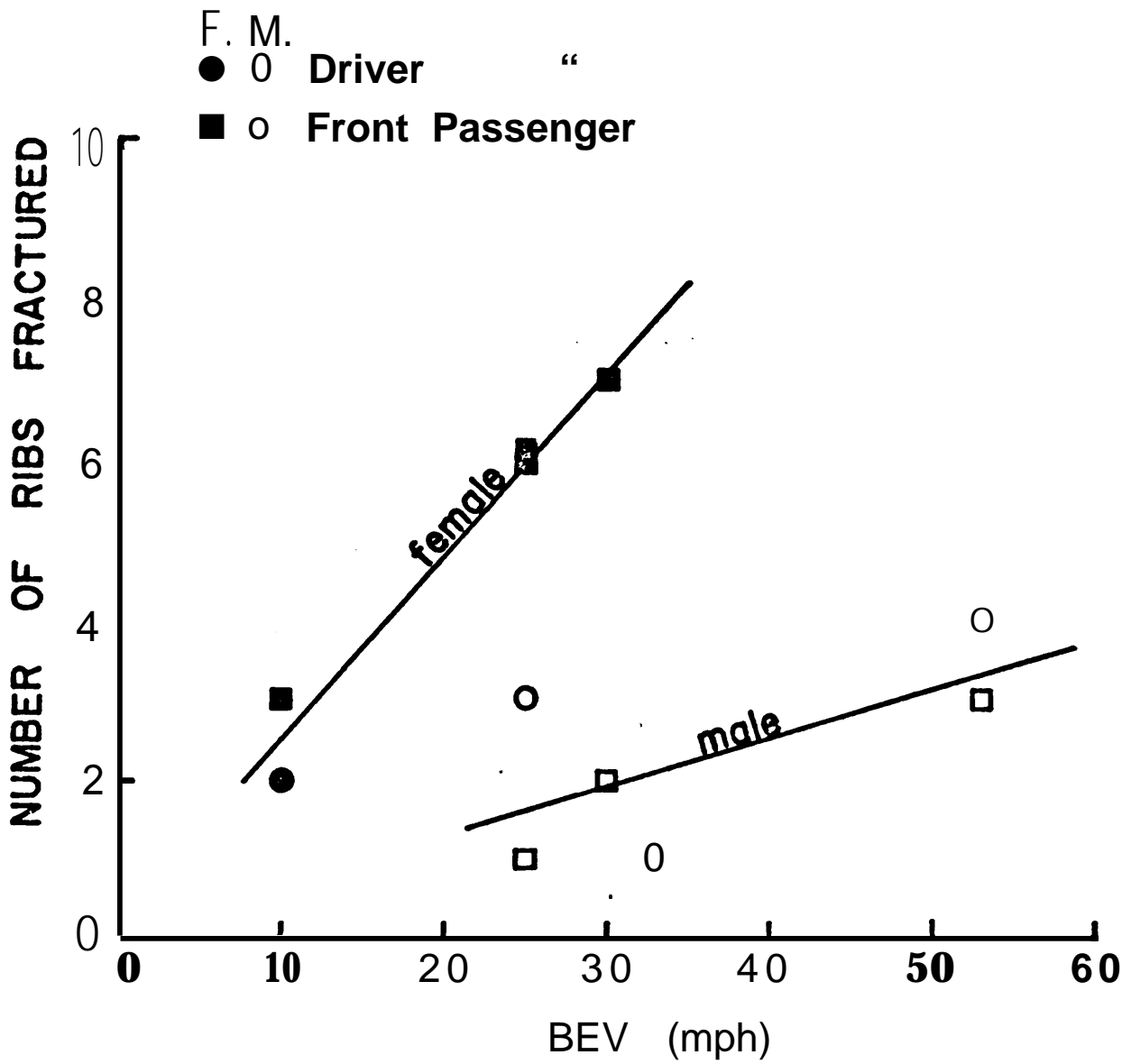

FIGURE 7 : RIB FRACTURES FOR MALE AND FEMALE OCCUPANTS AS A FUNCTION OF BARRIER EQUIVALENT VELOCITY.

○	0 - 9	MPH
+	10 - 19	"
□	20 - 29	"
△	30 - 39	"
▽	40 - 49	"
△	50 - 59	"

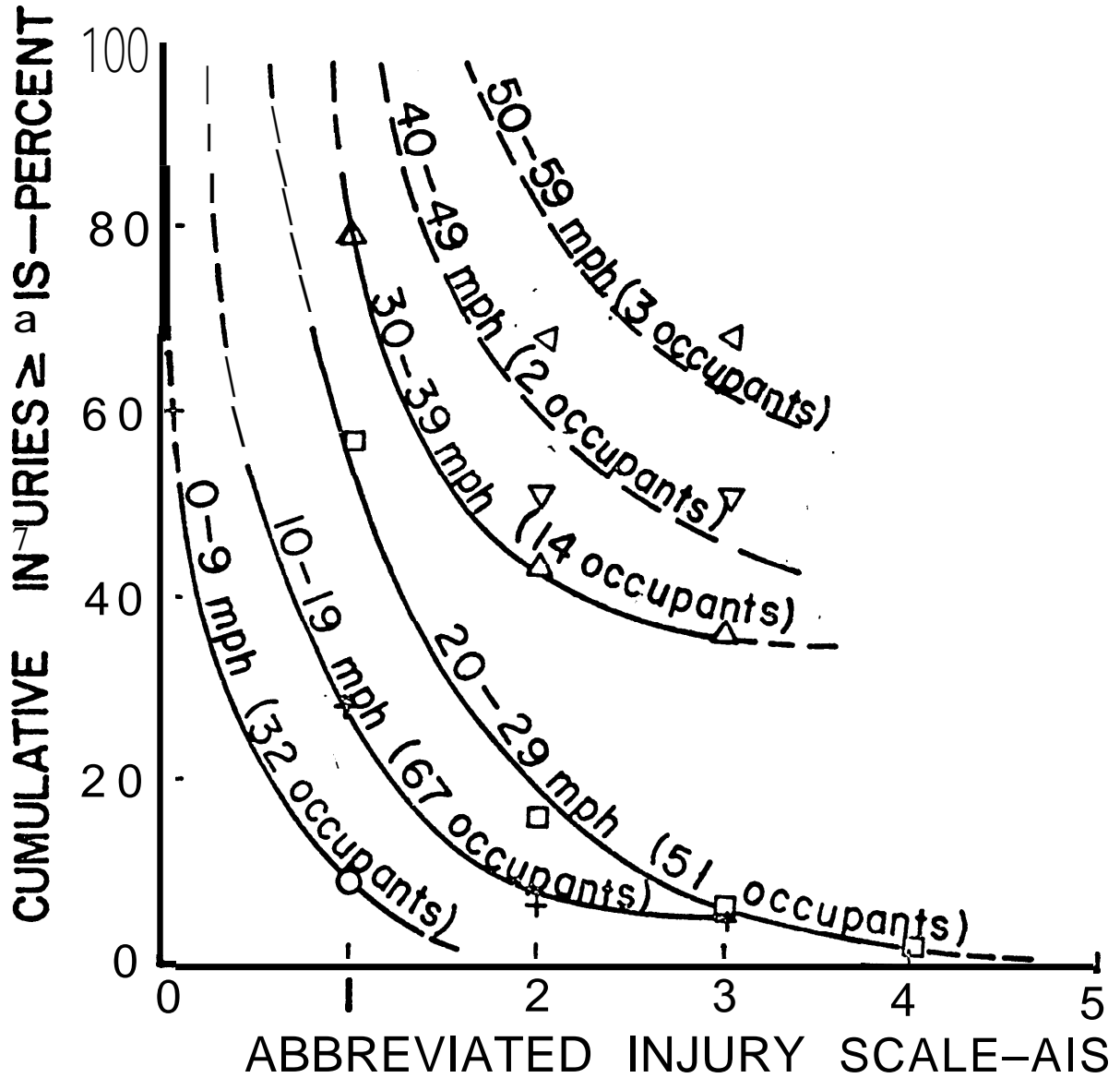

FIGURE 8: PERCENT OF CUMULATIVE INJURIES, EQUAL TO OR GREATER THAN, A GIVEN AIS LEVEL FOR 10 MPH INCREMENTS .

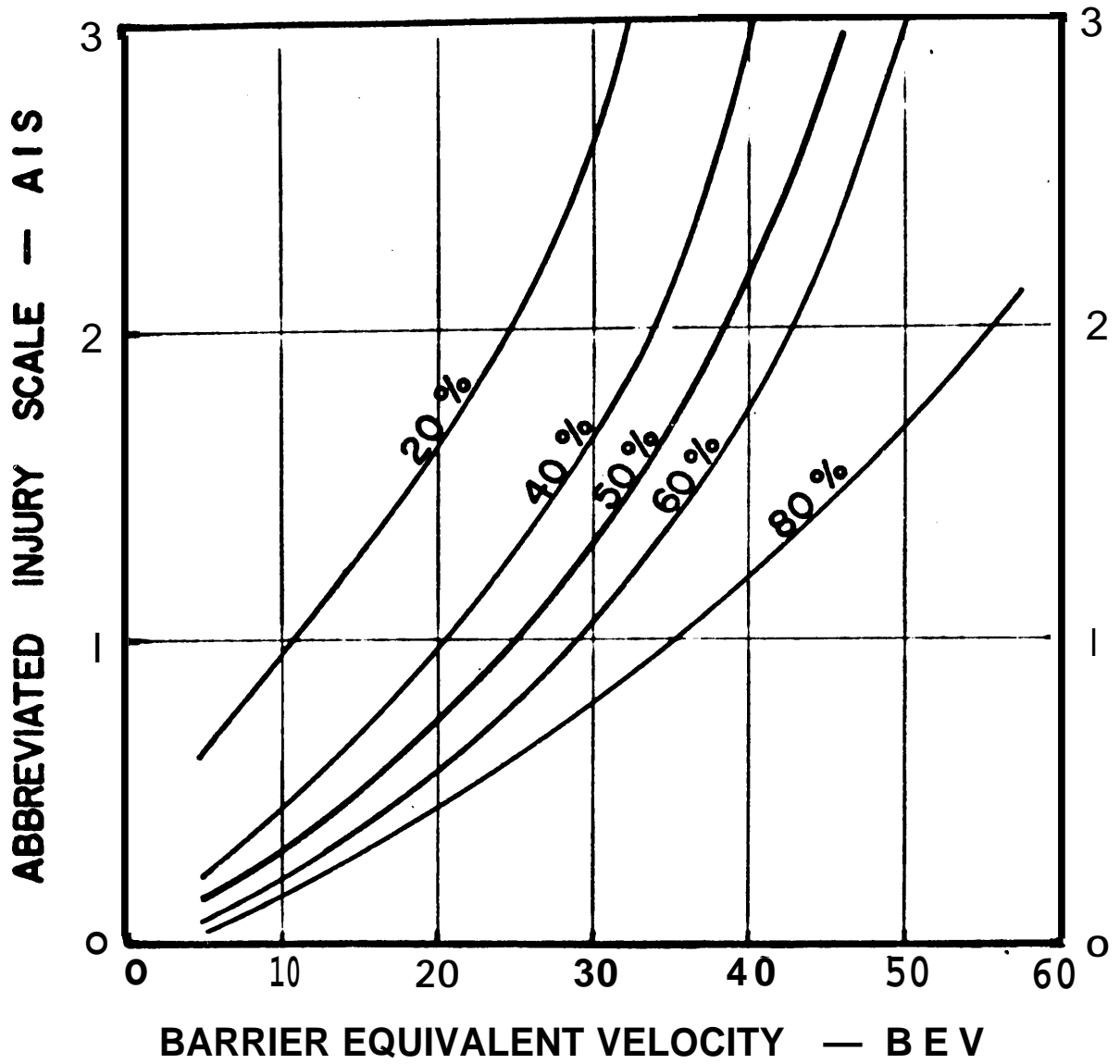

FIGURE 9 : INJURY AS A FUNCTION OF BARRIER EQUIVALENT VELOCITY FOR CUMULATIVE PER CENT OF INJURY